

NC Specifications / FANUC Series

Item	Specification	FANUC Series
Controlled axis	Max. feed axes	2 AXIS
	Feed axes	X/Z/(Cs)
	Max. simultaneously controlled axis	4
Operation functions	Least command increment	0.001mm / 0.0001"
	Pulse handle feed	X1, X10, X100
	Feedrate per minute	G98
Interpolation functions	Feedrate per revolution	G99
	Linear interpolation	G01
	Circular interpolation	G02, G03
	Dwell	G04
	Polar coordinate interpolation	G12.1, G13.1
	Cylindrical interpolation	G70.1
	Variable lead thread cutting	G34
	Continuous threading	
	Reference position return	G28
	Reference position return check	G27
Feed function	Rapid traverse rate override	F0, 25%, 50%, 100%
	Feedrate override	0~150%
Spindle function	Spindle orientation	
	Rigid tapping	
Tool functions	Tool number command	T4-Digt / T2-Digt
	Tool nose radius compensation	G40 ~ G42
	Tool offset pairs	
	Tool geometry/wear offset	GEOMETRY & WEAR DATA
	Tool life management	
	Tool path graphic display	
	Automatic tool offset	G36, G37
	Direct input of tool offset value measured B	
Program input	Absolute/incremental programming	
	Multiple repetitive cycle	G70 ~ G76
	Canned cycles	G90, G92, G94
	Inch/metric conversion	G20 / G21
	Program restart	
	Retraction for rigid tapping	
	Max. programmable dimension	±99999.999mm/±9999.9999"
	M function	M3 digit
	Custom macro	#100-#199, #500-#999
	Canned cycle for drilling	
	Direct drawing dimension programming	
	Programmable data input	G10
	Optional block skip	
	Workpiece coordinate system	G52 ~ G59
Number of registerable programs		
Setting and display	Alarm & Operator history display	ALARM & OPERATION DISPLAY
	Run hour and parts count display	RUNNING TIME & PART NO. DISPLAY
	Display spindle & servo overload	SPINDLE & SERVO LOAD DISPLAY
	Self-diagnosis function	
	Extended part program editing	COPY, MOVE, CHANGE OF NC PROGRAM
Data input/output	Display screen	10.4" color
	Memory card input/output	
Editing operation	USB memory input/output	
	Part program storage size	512Kbyte(1280m)
Manual guide i	Manual Guide i	Option

SMEC

SLV 500/500M (RH, LH)

VERTICAL TURNING CENTER



SMEC
SMEC America Corp.

14 West Forest Avenue Englewood, NJ 07631 USA
Office: +1 201-227-7632
Email: sales@esmecamerica.com

www.esmecamerica.com
www.youtube.com/smecmachinetoolsamerica



◆ Design and specifications subject to change without notice.

© SMEC 2019.09-NO.1

SMEC
SMEC America Corp.

Samsung
Machine Tools
Engineering
Company
SMEC

Company History

- 1988 - Started as **Samsung Heavy Industries** Machine Tools Business
- 1989 - Horizontal and vertical machining center technology partnership with **OKK Japan**
- 1991 - Turning center and vertical machining center technology partnership with **Mori Seiki**
- 1996 - 5-sided processing center technology partnership with **Toshiba**
- 1999 - Spun out from **Samsung Aerospace Industries** and established **SMEC Co., Ltd**
- 2018 - **SMEC America Corp** established to provide factory support to the distributor network and customers

SLV 500/500M

A Type : Chuck Size 12"

B Type : Chuck Size 15"

C Type : Chuck Size 18"

Strongest in class with superb structural design
Simultaneous heavy duty and precision turning

- High speed, precision and high rigidity spindle
- Stable machine structure
- Significantly reduced non-cutting time and high productivity

High Accuracy, High Rigidity Spindle

Main Spindle Structure

High torque main spindle motor is supported by strong Double Cylindrical Roller bearings and Angular Thrust bearings which allow heavy duty cutting and minimize acceleration/deceleration times.

Spindle nose(ASA) : **A2-8**

Spindle bearing diameter(front) : **Ø5.12 inch**

A2-8, 12"(15") chuck available

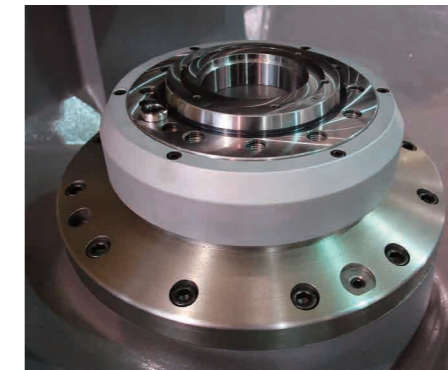
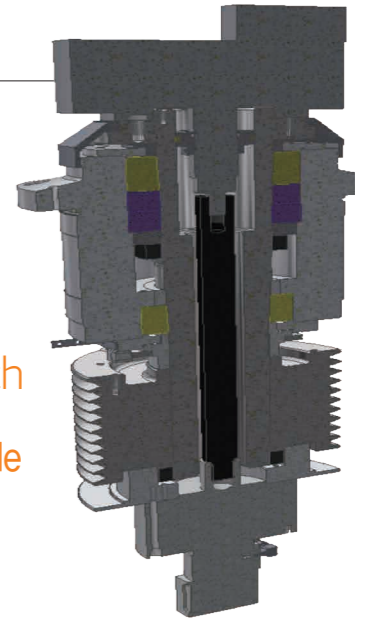

Spindle Power & Torque Diagram

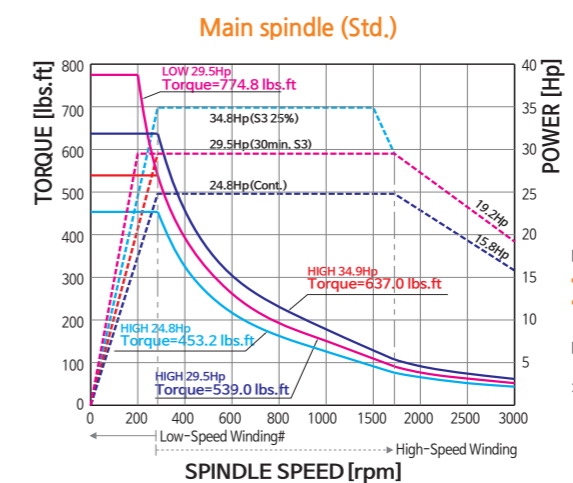

Main Spindle motor(Max./30min/Cont.) :
34.8/29.5/24.8 hp

Max. speed
: 3,000 rpm

An innovative high precision, heavy duty CNC Lathe, integrated with all of SMEC's advanced technology - SLV 500/500M



Spindle speed
3,000 rpm (12")
2,000 rpm (15"/18")

Max. machining diameter
19.69 inch

Max. machining length
18.31 inch

Rapid traverse(X/Z)
787.4/787.4 ipm

Highly Reliable and Rigid Structural Design

Ensure heavy duty and precision cutting with excellent structural design

SERVO TURRET



Indexing Time
0.18 sec(60Hz)

Number of tool positions
12 stations

High Speed, Heavy Duty Servo Turret

Driven by a reliable high torque servo motor, the 12-station heavy-duty turret indexes nonstop, bi-directionally with a fast 0.18 second from station to station. Large diameter 3 pieces precision Curvic coupling with 9,959 lbs of turret clamping force enables precision as well as heavy-duty cutting.

SLV500_M is equipped with standard 12-station BMT65 turret, capable of accepting rotary tools at any station.

CLAMP FORCE

9,959 lbs



Milling Motor Torque Diagram

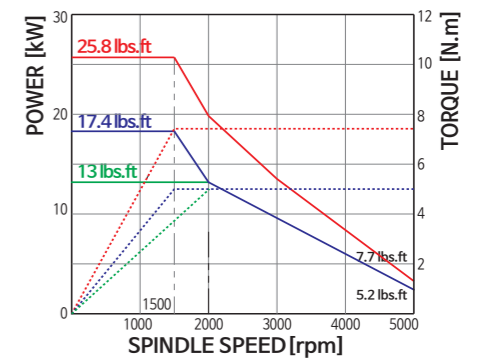

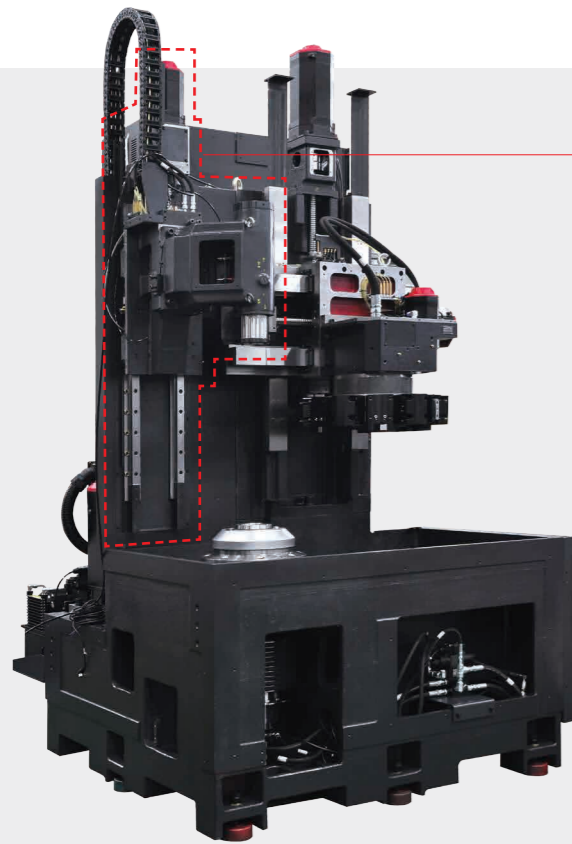

Servo Tailstock (Special Option)

- Tailstock Drive Mechanism : Servo Motor (2.15Hp)
- Tailstock travel : 17.72"
- Tail stock Diameter : Ø4.33" - Tail stock taper type : MT-5
- Quill Drive Mechanism : Hydraulic - Quill travel : 3.15"

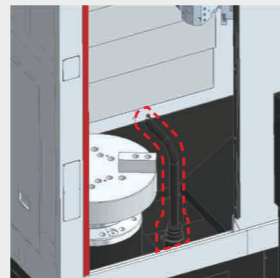

Tool Presetter (Special Option)

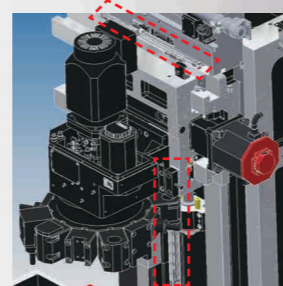

X/Z Linear Scale (Special Option)

- Spec. : ±5µm

Main Body Construction

The main body of SLV 500/500M is consisted of one piece meehanite cast iron bed, wide column, anti-heat displacement spindle and headstock, and integral Box way construction with anti-friction mating way surfaces that ensure unsurpassed long term rigidity and superior accuracy.

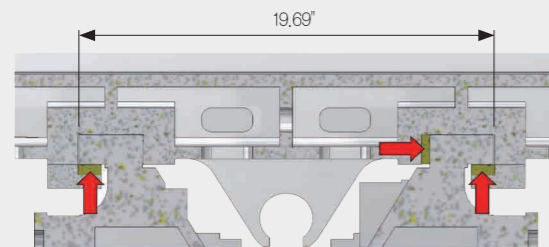

Three(3) adjustable Gibs on X and Z axis provide easier maintenance as well as long term rigidity and accuracy

Column Span : The largest in its class
19.69 inch



Easy Chip Removal and High Volume Coolant System.

Large volume of flushing coolant allows minimal chip build-up, and slanted splash guard design effectively removes the chip out from the machine.

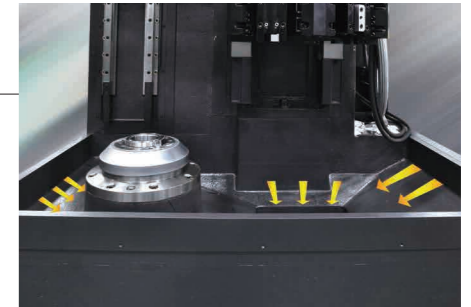

Motor
1.48 Hp
Discharge Capacity
73.97 gal

Working Range

Unit : inch

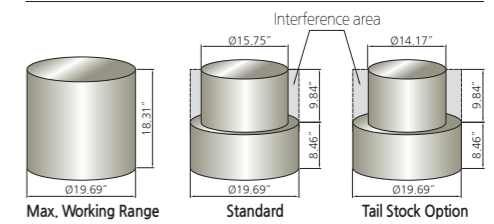

Operator convenience pendant type control panel

- High-Speed and High Quality Machining
- Excellent Control Functions
- Focusing on Minimizing Downtime High Reliability and Easy Maintenance
- Operator convenient pendant type control panel

Pre-tensioned and Double Anchored Ballscrews

All axes ballscrews are pre-tensioned, heat treated, and fixed by double anchors on both ends, providing ultimate rigidity and minimal thermal growth.



Reliable Lubrication Dispenser

Lubrication pump adopted which is one of the most reliable brand and offers exact amount of oil on each face.

Capacity : **0.79 gal**



High Precision

Surface Roughness

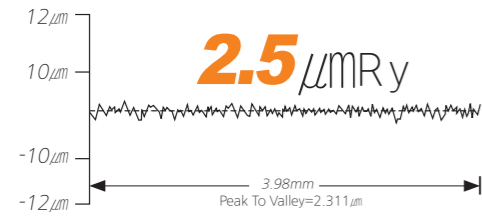

Model : SLV 500

Roundness

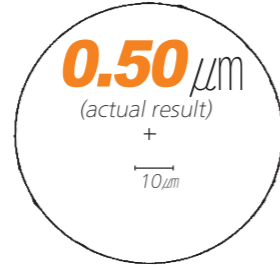

Cutting condition	
Tool	Diamond tool <nose radius 0.020 inch>
Material	AL150<Aluminum>
Cutting speed	198 m/min
Feedrate	0.05 mm/rev
Depth of cut	0.1 mm
Outer diameter	200 mm
Filter	1-50

Processing Speed

Turning Performance (material:SM45C) SLV 500

Heavy-duty cutting (O.D) <25mm×25mm qualified tool>

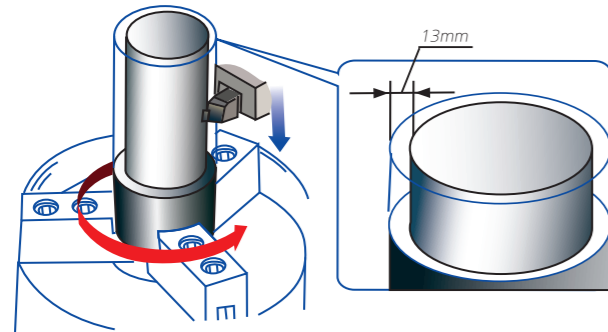

Spindle speed
357 rpm
Cutting speed
142 m/min
Depth of cut
13 mm <Spindle Load 65%>
Feedrate
0.3 mm/rev

Machine Dimensions

Unit : inch

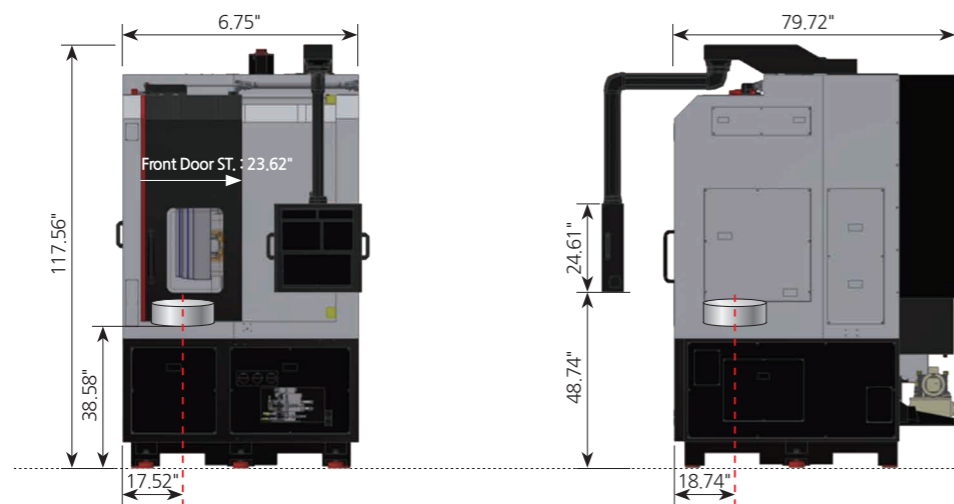

Tool Holders & Sleeves

Unit : inch

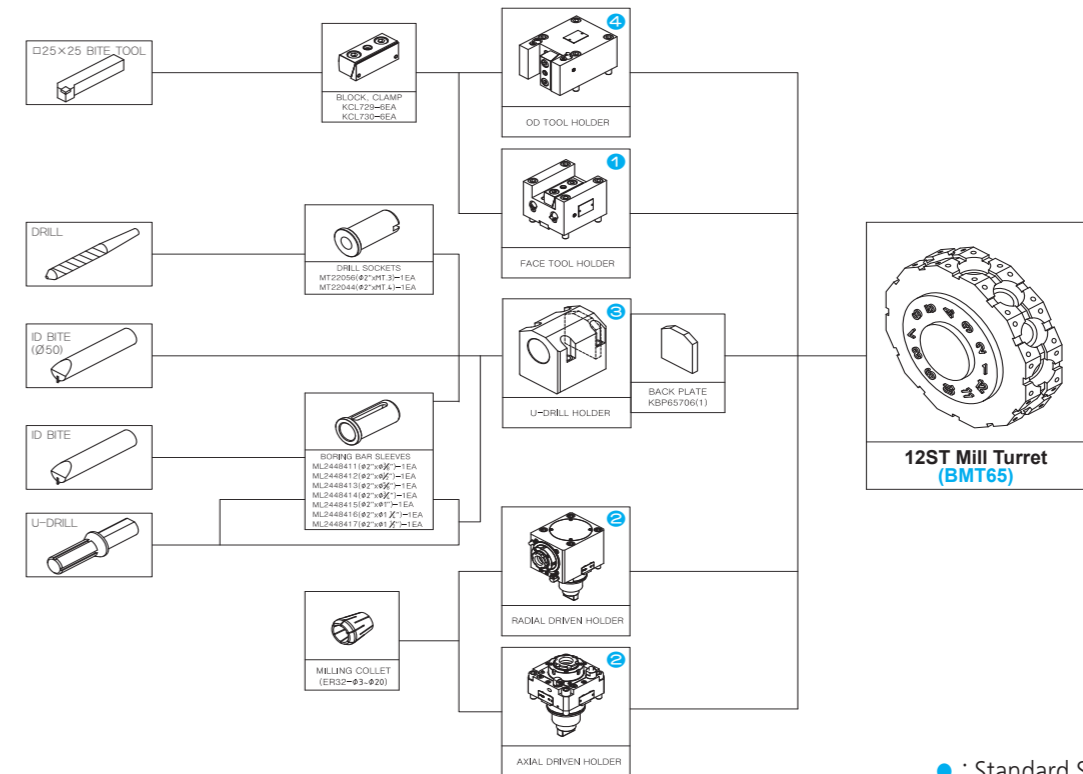
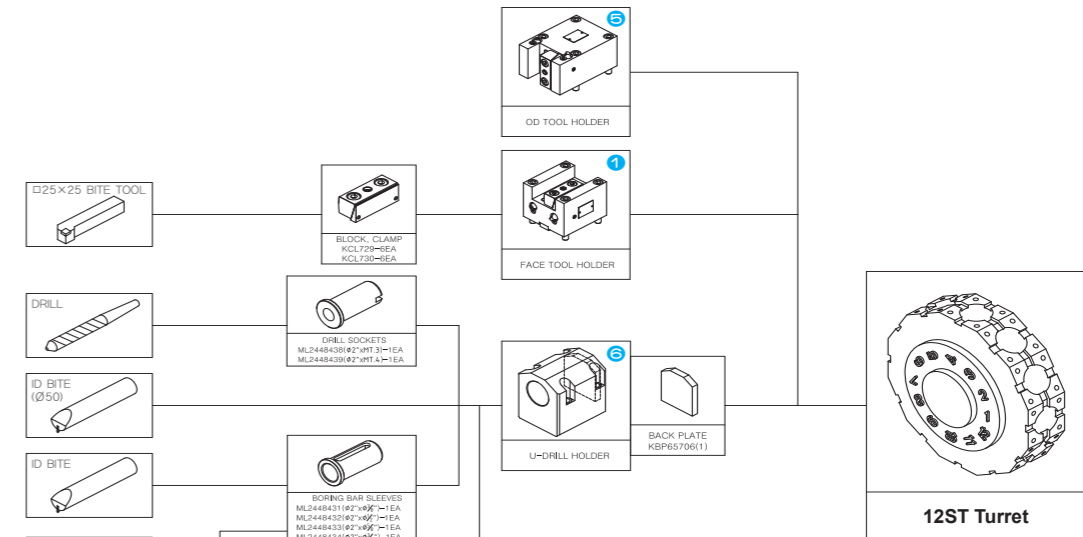

● : Standard Set Numbers

Work Range

Unit : inch

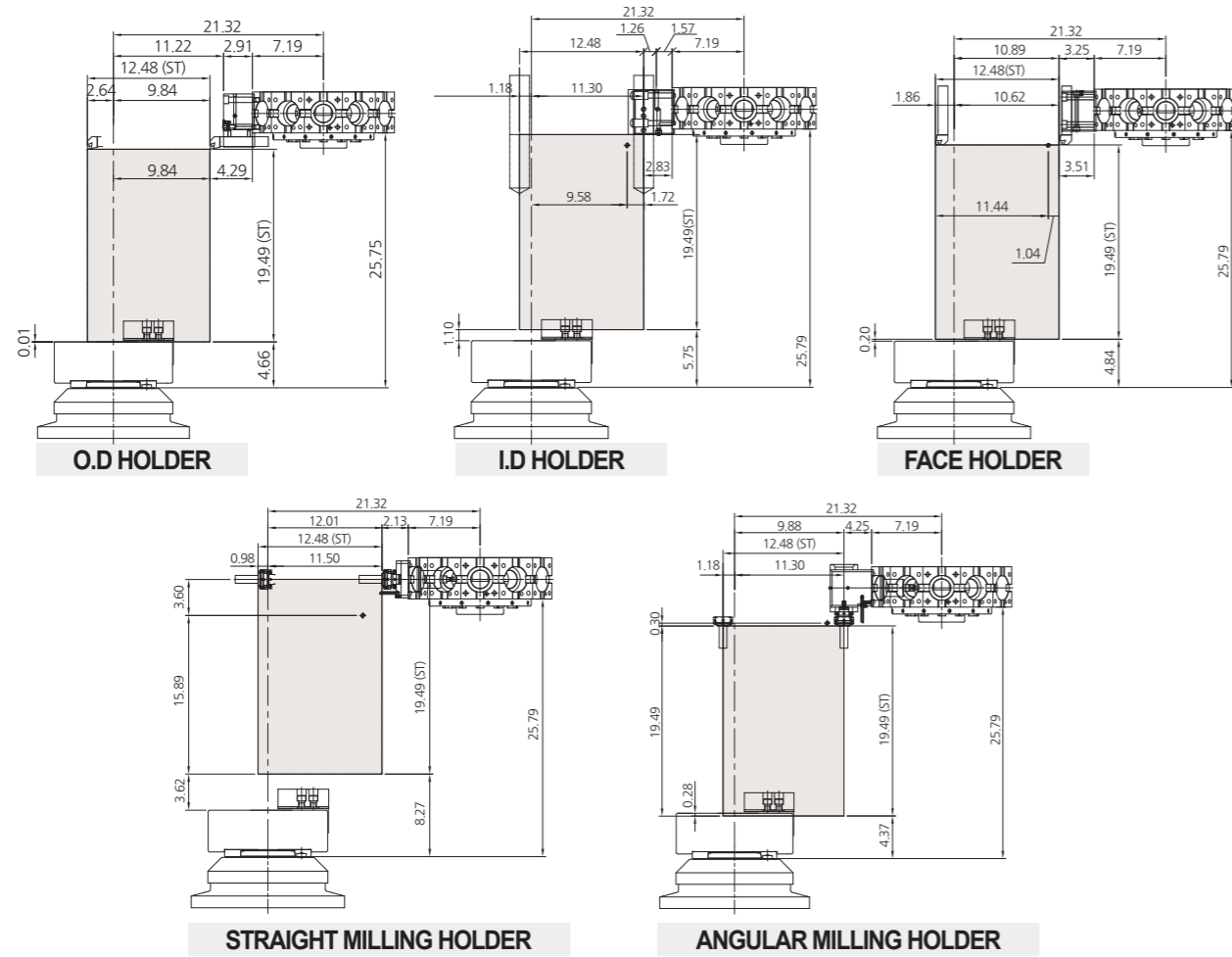

Turret Interference

Unit : inch

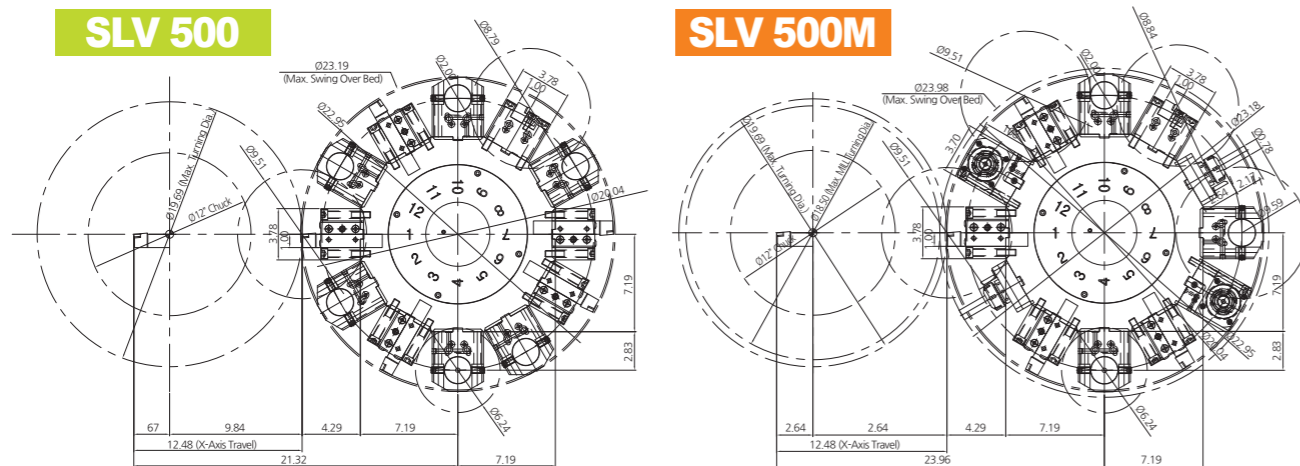

Major Specifications

DESCRIPTION	SLV 500 (RH/LH)			SLV 500M (RH/LH)		
	A Type	B Type	C Type	A Type	B Type	C Type
Chuck	Chuck size inch 12 15 18					
Capacity	Swing over bed inch 27.6 27.6 27.6					
	Swing over cross slide(with Tailstock) inch 15.7(14.2) 15.7(14.2) 15.7(14.2)					
	Max. turning diameter inch 19.7 19.7 19.7					
	Max. milling diameter inch - - -					
Main spindle	Max. machining length inch 18.3 18.3 18.3					
	Spindle speed rpm 3,000 2,000 2,000					
	Spindle nose ASA A2-8 A2-8 A2-8					
	Draw tube ID inch - - -					
	Spindle bore diameter inch 2.4 2.4 2.4					
Travels	Motor (Cont/Max) hp 24.8/34.8 24.8/34.8 24.8/34.8					
	X-axis travel inch 12.5 12.5 12.5					
	Z-axis travel inch 19.5 19.5 19.5					
	X-axis Rapid traverse rate ipm 787 787 787					
Turret	Z-axis Rapid traverse rate ipm 787 787 787					
	number of tool stations ea 12 12 12					
	Turning tool shank size inch 1 1 1					
	Boring bar diameter inch 2 2 2					
	indexing time sec 0.18 0.18 0.18					
Tailstock	rotary tool spindle speed rpm - - -					
	rotary tool motor(Cont/Max) hp - - -					
	quill diameter inch [4.3] [4.3] [4.3]					
Machine	quill stroke inch [17.7] [17.7] [17.7]					
	spindle taper MT [MT5] [MT5] [MT5]					
	Size(with Side Chip conveyor)LxWxH inch 65.7(108.2)x100x131.5 65.7(108.2)x100x131.5					
Electric power supply	Size(with Rear Chip conveyor)LxWxH inch 65.7x100(160.6)x131.5 65.7x100(160.6)x131.5					
	weight lbs 15,652 15,873					
	Coolant tank capacity Liter 250 250					
	Controller FANUC					

※Design and specifications subject to change without notice.

[] : Option

Standard Accessories

- Coolant unit
- Work light
- S/G & Rear coolant tank
- Tool & work box
- Hyd. Solid chuck (12")
- Soft jaw
- Leveling unit
- Chuck clamp foot switch
- Shower coolant unit
- Chuck pressure switch
- 3 Color patrol lamp
- 10.4" LCD monitor
- Auto lubrication pump
- Manual & Parts list
- Safety precaution name plate
- Door interlock

Optional Accessories

- Hard jaw
- Chip conveyor & bucket (side/rear) (Hinge/Scraper)
- Chip bucket
- Special Chuck
- Dual pressure chucking
- Auto-door
- Air gun
- Air blower
- Oil skimmer
- Chuck coolant
- Coolant gun
- Coolant chiller
- Coolant pressure switch
- Coolant level switch
- High pressure coolant
- Mist collector
- Transformer
- Tool presetter (Removable)
- Linear scale (X,Z)
- Work Counter
- CE Spec.
- Tail stock