

■ NC Unit Specifications / FANUC Series

Item	Specification	Qi-TF
Controlled axis	Max. feed axes	4 AXIS
	Feed axes	X/Z/(Cs)
	Max. simultaneously controlled axis	4
Operation functions	Least command increment	0.001mm / 0.0001"
	Pulse handle feed	X1, X10, X100
	Feedrate per minute	G98
Interpolation functions	Feedrate per revolution	G99
	Linear interpolation	G01
	Circular interpolation	G02, G03
	Dwell	G04
	Polar coordinate interpolation	G12, 1, G13, 1
	Cylindrical interpolation	G70, 1
	Variable lead thread cutting	G34
	Continuous threading	
	Reference position return	G28
	Reference position return check	G27
Feed function	Rapid traverse rate override	F0, 25%, 50%, 100%
	Feedrate override	0~150%
Spindle function	Spindle orientation	
	Rigid tapping	
Tool functions	Tool number command	T2-Digt
	Tool nose radius compensation	G40 ~ G42
	Tool offset pairs	
	Tool geometry/wear offset	GEOMETRY & WEAR DATA
	Tool life management	
	Tool path graphic display	
	Automatic tool offset	G36, G37
	Direct input of tool offset value measured B	
Program input	Absolute/incremental programming	
	Multiple repetitive cycle	G70 ~ G76
	Canned cycles	G90, G92, G94
	Inch/metric conversion	G20 / G21
	Program restart	
	Retraction for rigid tapping	
	Max. programmable dimension	±99999.999mm/±9999.9999"
	M function	M3 digit
	Custom macro	
	Canned cycle for drilling	
	Direct drawing dimension programming	
	Programmable data input	G10
	Optional block skip	
	Workpiece coordinate system	G52 ~ G59
Number of registerable programs	400EA	
Setting and display	Alarm & Operator history display	ALARM & OPERATION DISPLAY
	Run hour and parts count display	RUNNING TIME & PART NO. DISPLAY
	Display spindle & servo overload	SPINDLE & SERVO LOAD DISPLAY
	Self-diagnosis function	
	Extended part program editing	COPY, MOVE, CHANGE OF NC PROGRAM
	Display screen	10.4" color
Data input/output	Memory card input/output	
	USB memory input/output	
Editing operation	Part program storage size	512Kbyte(1280m)
Manual guide i	Manual Guide i	

SMEC

SL 4500 series

CNC TURNING CENTER



SMEC
SMEC America Corp.

14 West Forest Avenue Englewood, NJ 07631 USA
Office: +1 201-227-7632
Email: sales@esmecamerica.com

www.esmecamerica.com
www.youtube.com/smecmachinetoolsamerica



◆ Design and specifications subject to change without notice.

© SMEC 2019.09-NO.1

SMEC
SMEC America Corp.

SMEC



Company History

- 1988 - Started as **Samsung Heavy Industries** Machine Tools Business
- 1989 - Horizontal and vertical machining center technology partnership with **OKK Japan**
- 1991 - Turning center and vertical machining center technology partnership with **Mori Seiki**
- 1996 - 5-sided processing center technology partnership with **Toshiba**
- 1999 - Spun out from **Samsung Aerospace Industries** and established **SMEC Co., Ltd**
- 2018 - **SMEC America Corp** established to provide factory support to the distributor network and customers

SMEC'S Advanced Engineering and Machine Design

- Cast iron structure for superior dampening characteristics and thermal displacement
- Rigid 45 degree slant bed design for heavy-duty machining
- Torque tube design to minimize bending and twisting
- Integrated box ways for long-term rigidity and heavy-duty machining

SL 4500
SL 4500CX(CXM)
SL 4500CL(CLM)

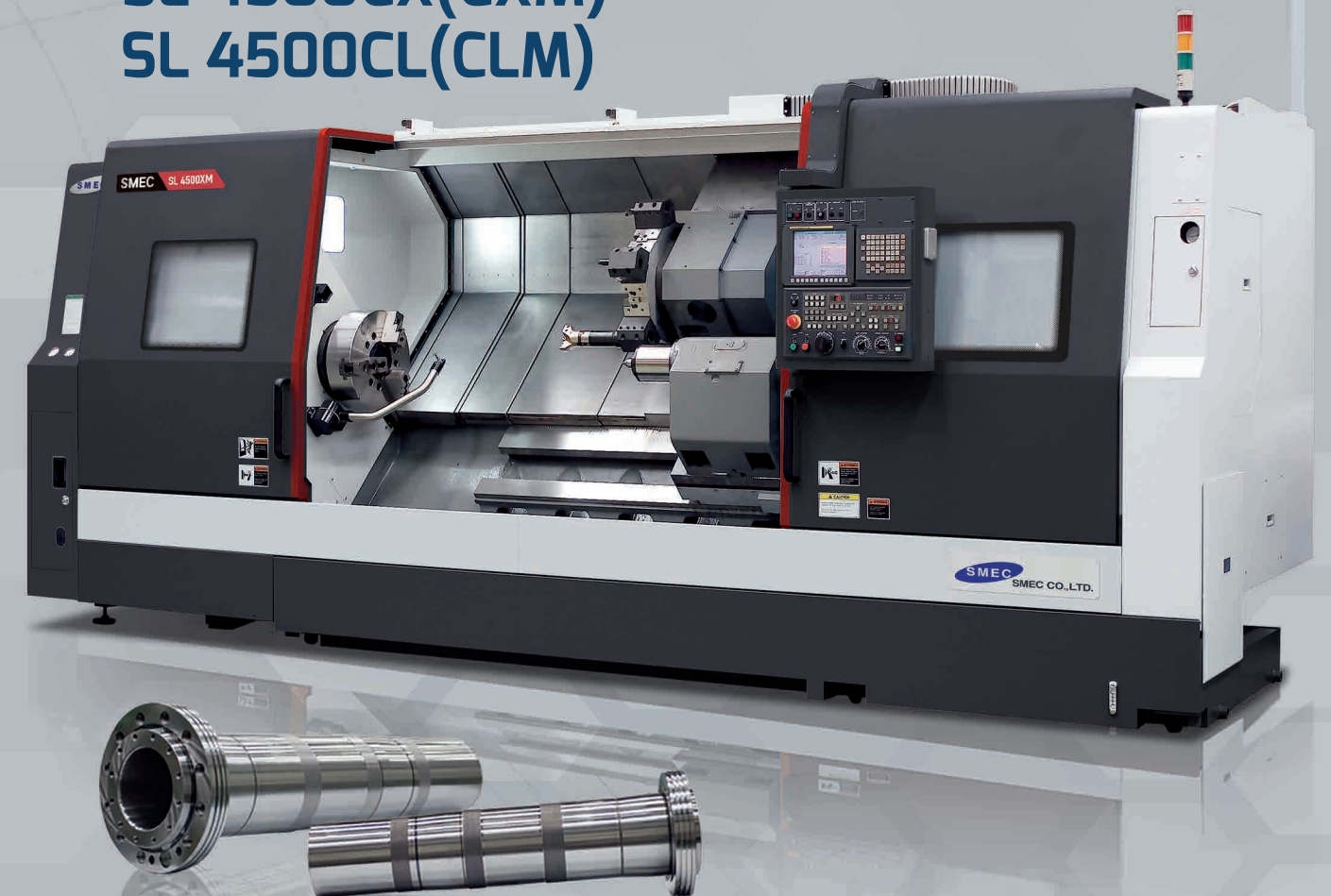

High Accuracy, High Rigidity Spindle

SL 4500CX(CXM) are heavy duty, ultra precision Turning Center, combined with SMEC's advanced technological features.

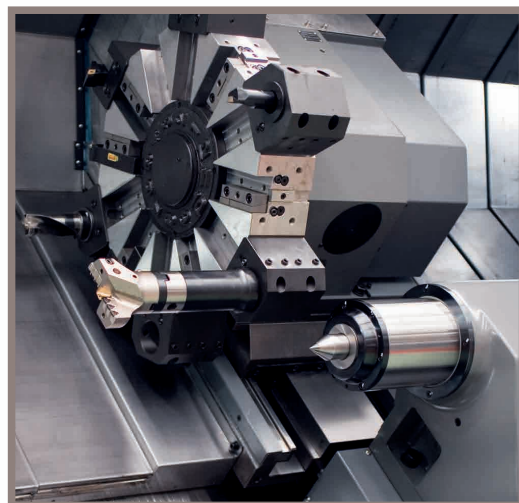

Spindle Speed
1,200 rpm

Spindle Motor(cont./max)
40/60 hp

Rapid Travel(X/Z)
787/787 ipm(SL4500)
787/709 ipm(SL4500CX/CXM)
787/394 ipm(SL4500CL/CLM)

Feed Motor(X/Z)
9.3/8 hp

Max. Turning Diameter
27.2 inch (SL4500/CX/CL)
24.4 inch (SL4500CXM/CLM)

Max. Turning Length
49.2 inch (SL 4500)
88.8 inch (SL 4500CX/CXM)
120 inch (SL 4500CL/CLM)

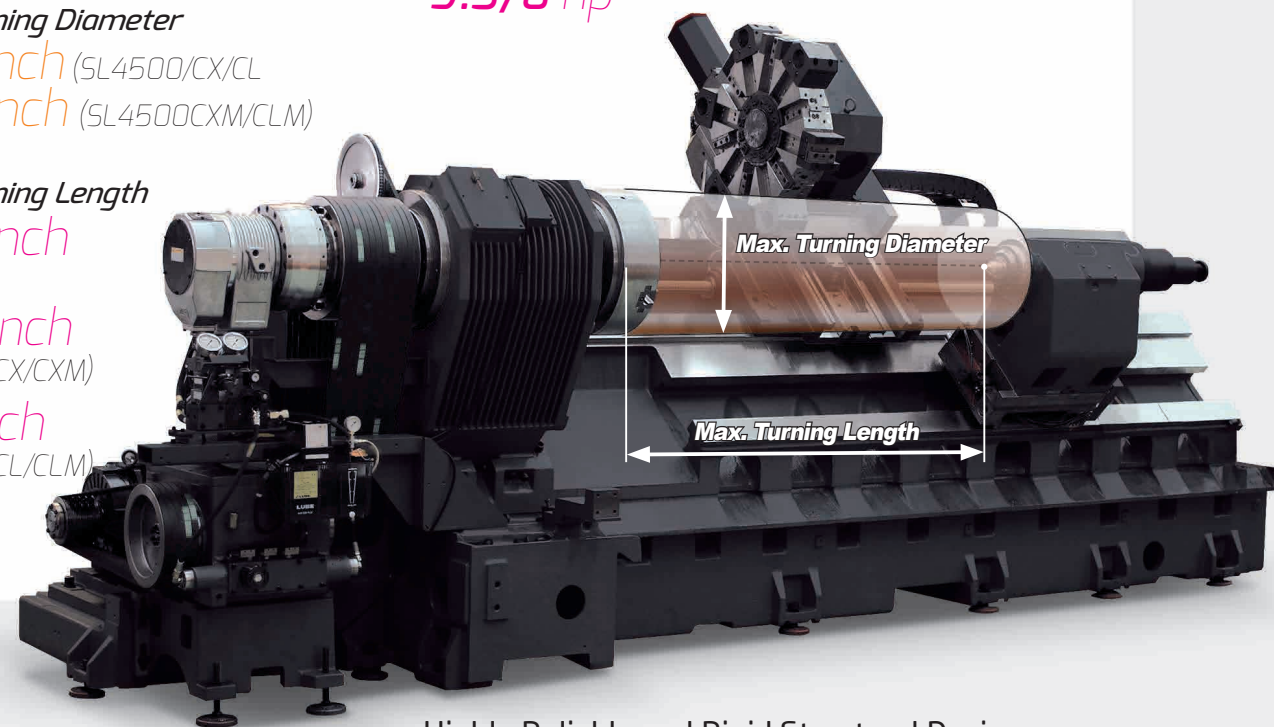

Highly Reliable and Rigid Structural Design

- One piece Meehanite casting with heavily ribbed torque tube design
- Rigid bed supports for powerful cutting
- Excellent vibration dampening and thermal displacement design

Output Converting Transmission

Equipped as standard feature, high Output Converting Transmission provides heavy-duty machining.

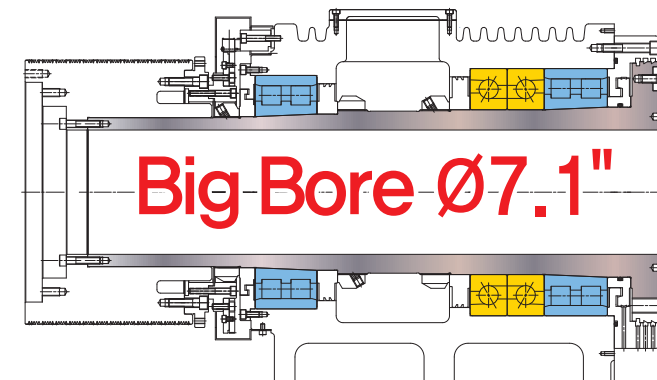
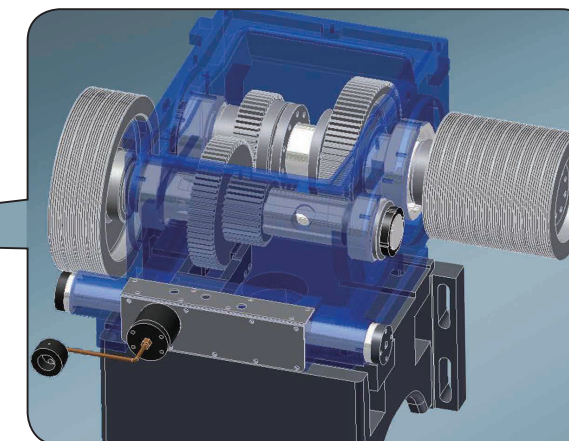
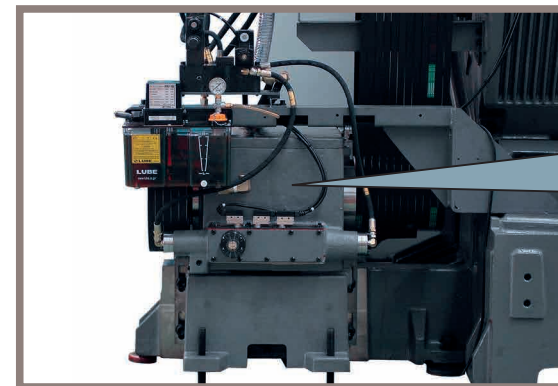

Pin Tube Rib Design for Minimal Axis Heat Transfer

Radiator fan-like pin tube rib design dissipates heat generated by axis movements, maintaining minimal thermal expansion.

Spindle Power & Torque Diagram

Unit : inch

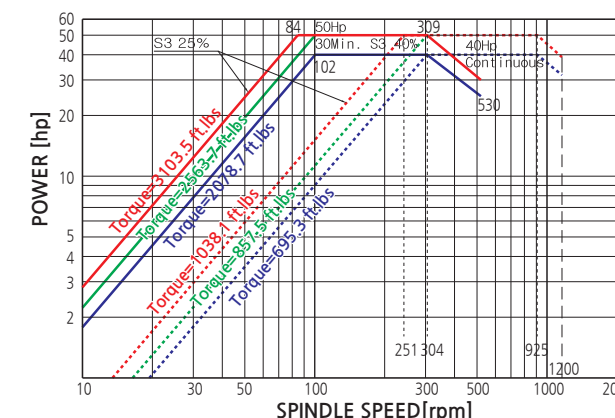

Machine Structure

SL 4500CX (High Speed Servo Turret)

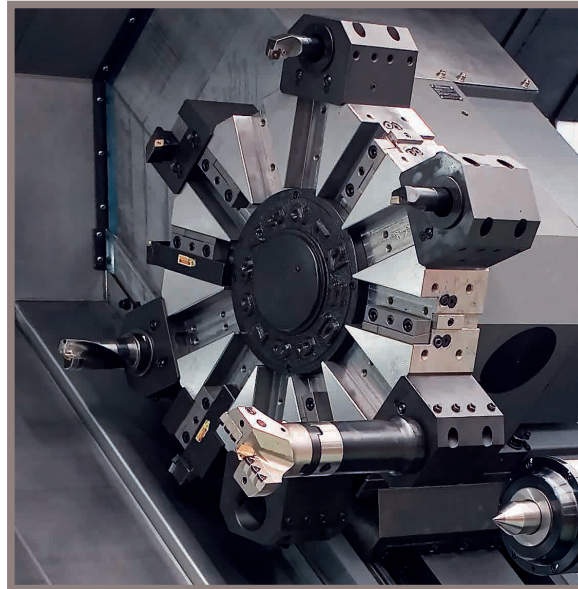

Indexing time

0.25 sec.

Number of tool positions

12 stations

High Speed, Heavy Duty Servo Turret

Driven by a high torque servo motor, the 12-station heavy-duty turret can accept tools on both the left and right side of each station. Turret indexing (repeatability $\pm 0.0002''$) is non-stop, bi-directional with a fast 0.2 second next station index time. Large diameter ($\varnothing 9.05''$) precision Curvic coupling with 25,000 lbs clamping force enables precision as well as heavy-duty cutting.

SL 4500CXM (BMT High Speed Turret)

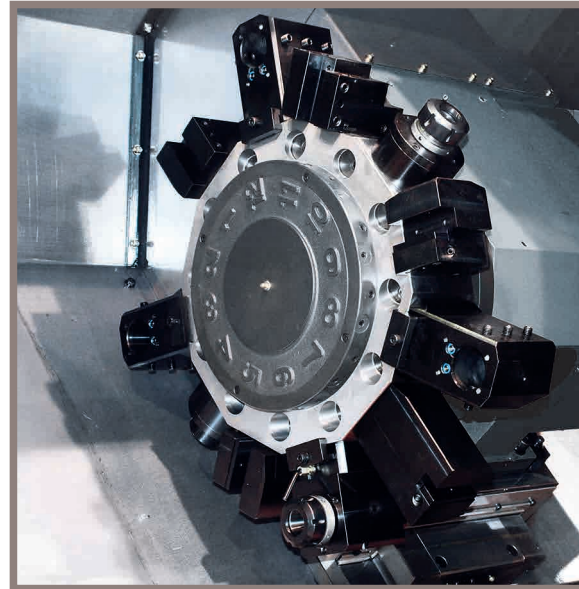

Indexing time

0.25 sec.

Number of tool positions

12 stations

BMT Milling Turret (M Type)

SL 4500CXM is equipped with standard 12-station BMT turret capable of accepting rotary tools at any station, providing flexible machining through various machining operations in just one set-up. Each BMT holder is securely tightened by 4 screws, allowing the turret to perform heavy-duty cutting, milling and drilling operations. Turret indexing is non-stop, bi-directional with a fast 0.2 second next station index time.

Turret Torque Diagram

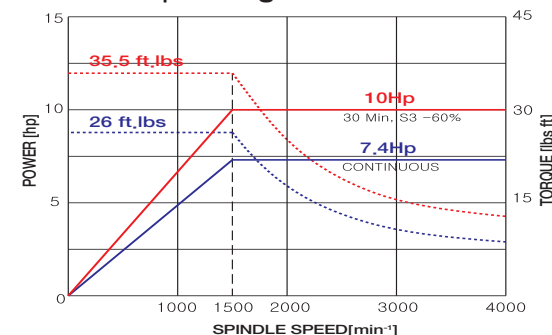

Machine Structure

Rigid 45 degree Slant Bed

45 degree slant torque tube design bed and wide guide slide way ensure long term rigidity and machining accuracy.

Featuring superior workability and chip-discharging capability, the bed is designed in a single tube structure boasting strong durability even in heavy-duty cutting.

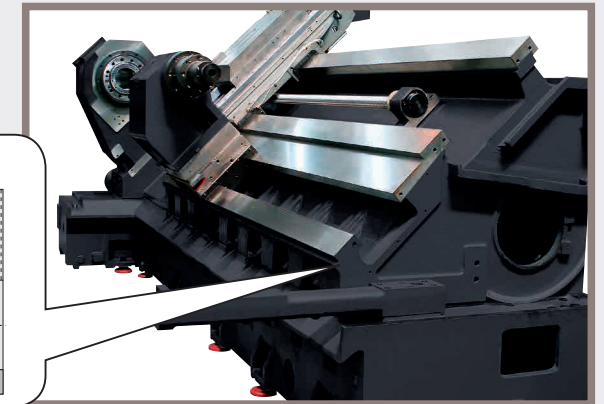
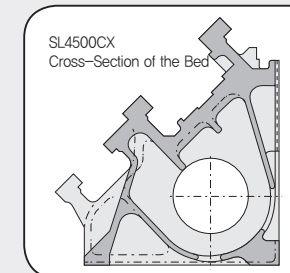

Swivel Operation Panel

Swivel operation panel of 10.4 inch color TFT LCD monitor can turn to 90 degree, providing operators with easy access to the control panel while working on the machine.

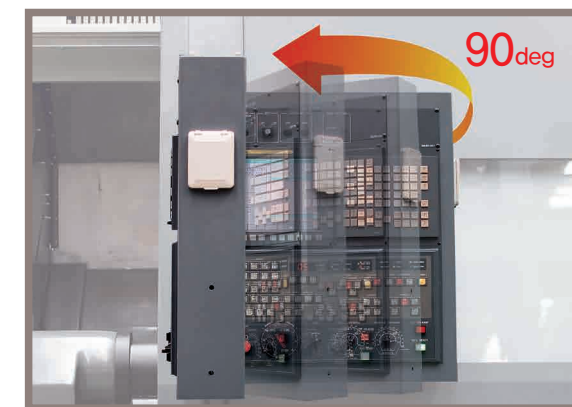

Pre-tensioned and Double Anchored Ballscrews

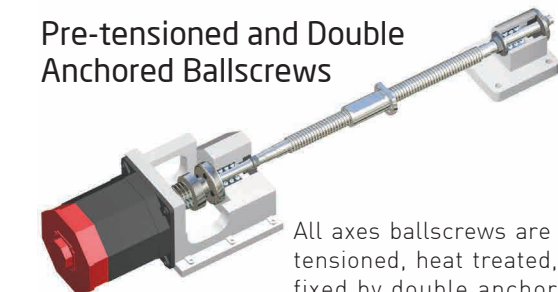

All axes ballscrews are pre-tensioned, heat treated, and fixed by double anchors on both ends, providing ultimate rigidity and minimal thermal growth.

Hexahedral Slide Way Frame

Wide integral way is machined from the casting, induction hardened and precision ground to ensure long-term rigidity, machining accuracy and heavy-duty machining.

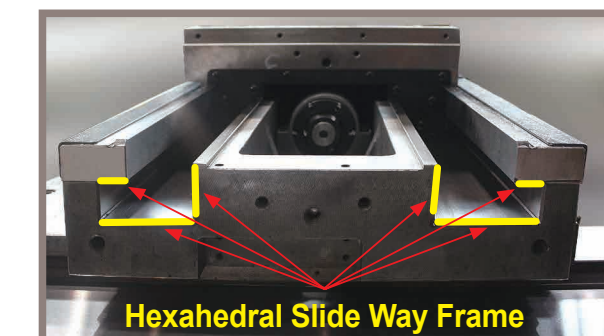

Tailstock

The programmable tailstock body mounted on wide guide ways ensure rigid work piece support.

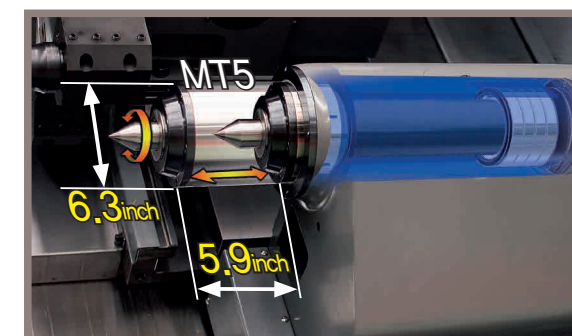

■ High Precision

Surface Roughness <O.D. cutting>

Roundness

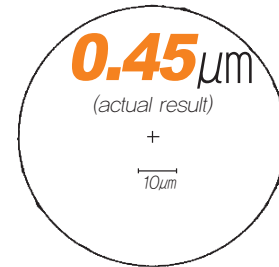
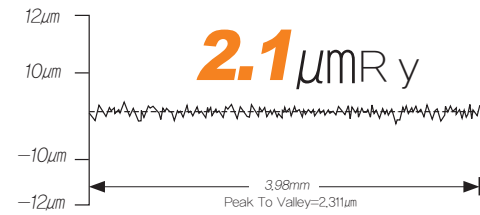

Cutting condition	
Tool	Diamond tool (nose radius 0.020 inch)
Material	AL150(Aluminum)
Cutting speed	745.6 fpm
Feedrate	0.0020 ipr
Depth of cut	0.004inch
Outer diameter	7.9inch
Filter	1-50

•Model : SL 4500CX

■ Processing Speed

Turning Performance (material:SM45C) SL 4500CXM

Heavy-duty cutting (O.D) <1 1/4 inch x 1 1/4 inch qualified tool>

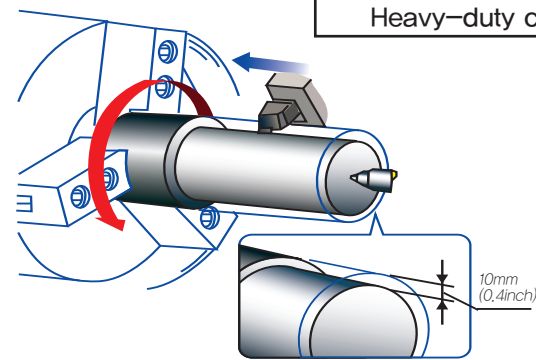

Spindle Speed
367 rpm

Cutting Speed
150 m/min (492 fpm)

Depth Of cut
0.4 inch <Spindle Load 65%>

Feedrate
0.4 mm/rev (0.11 ipr)

■ Standard Accessories

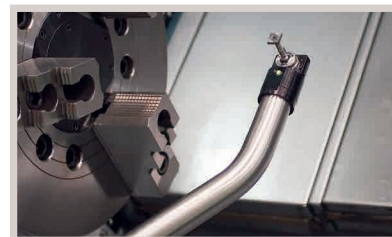

Tool Presetter



Automatic Lubricator

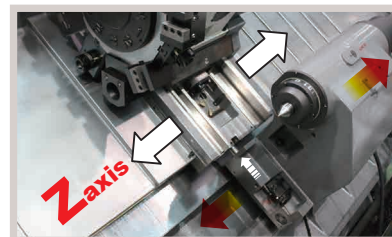

Programmable Tailstock

■ Optional Accessories

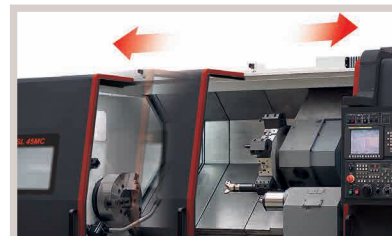

Auto Door



Chip Conveyor

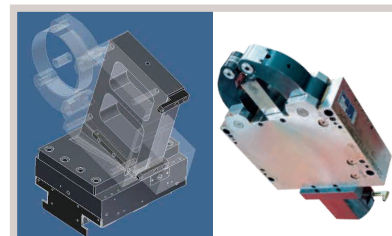

Steady Rest & Preparation

■ Tooling System

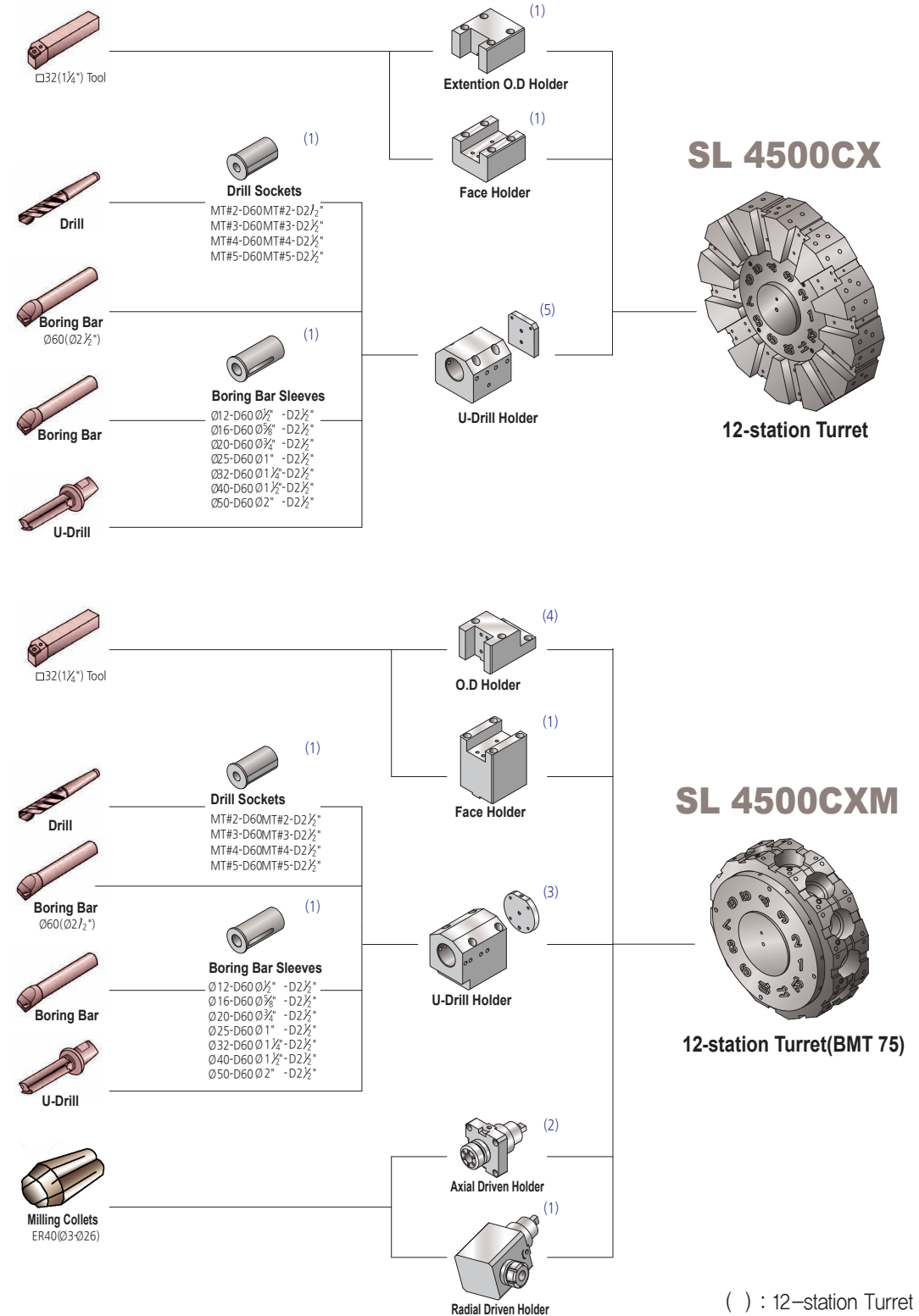

Machine Dimensions

SL 4500CX(CXM)

Unit : inch

[] : SL 4500CL(CLM)

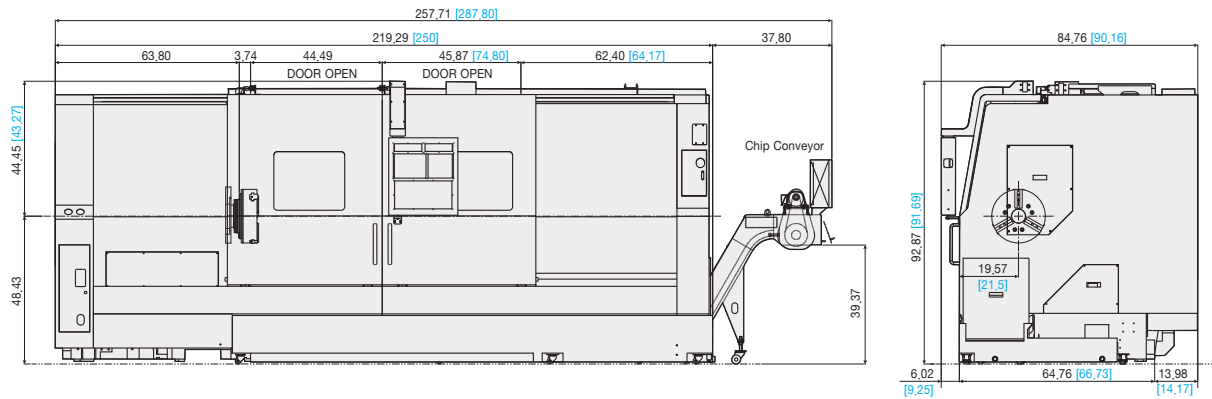

Turret Head Interference

STD TURRET (STD 12 station)

MILL TURRET (BMT 75)

Unit : inch

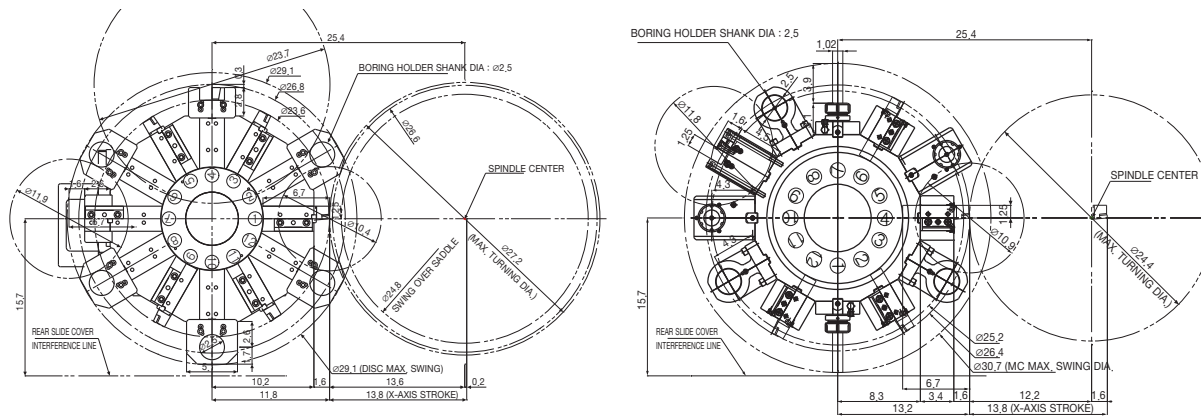

Work Range

SL 4500CX

SL 4500XM

Unit : inch

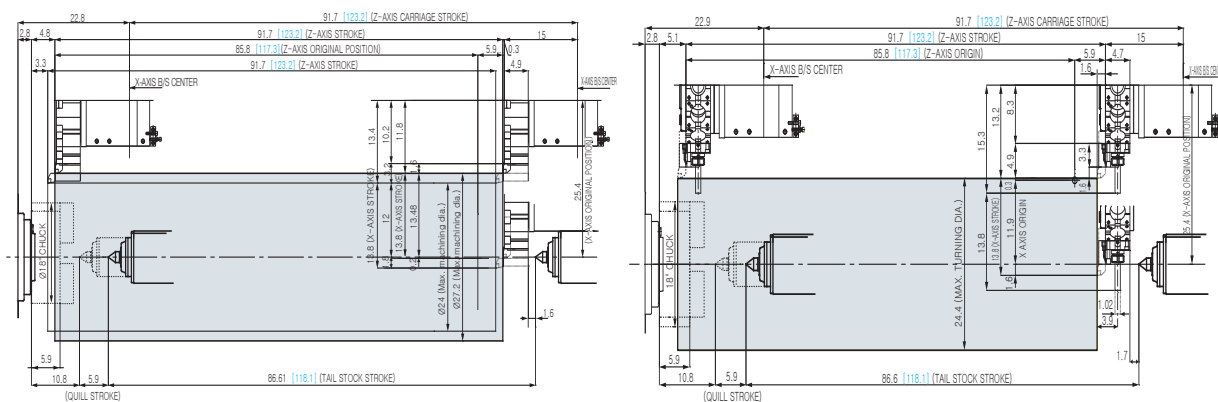

[] : SL 4500CL

[] : SL 4500CLM

Major Specifications

DESCRIPTION		SL 4500	SL 4500CX(CXM)	SL 4500CL(CLM)	
Chuck	Chuck size	inch 18[24]	24	24	
	CAPACITY	Swing over bed	inch 30.5	30.5	30.5
		Swing over cross slide	inch 24.8	24.8	24.8
		Max. turning diameter	inch 27.2	27.2(24.4)	27.2(24.4)
		Max. milling diameter	inch -	(28)	(28)
Max. machining length	inch 49.2	88.8	120.2		
MAIN SPINDLE	Spindle speed	rpm 1,800[1,200]	1,200	1,200	
	Spindle nose	ASA A2-11[A2-15]	A2-15	A2-15	
	Draw tube ID	inch 4.6[6.6]	6.6	6.6	
	Spindle bore diameter	inch 5.1[7.1]	7.1	7.1	
	Motor (Cont/Max)	hp 40/60	40/60	40/60	
TRAVELS	x-axis travel	inch 13.8	13.8	13.8	
	z-axis travel	inch 52.1	91.7	123.2	
	x-axis Rapid travers rate	ipm 787	787	787	
	z-axis rapid travers rate	ipm 787	709	394	
	TURRET	number of tool stations	ea 12	12(BMT75)	12(BMT75)
Turning tool shank size		inch \varnothing 1.25	\varnothing 1.25	\varnothing 1.25	
Boring bar diameter		inch \varnothing 2.5	\varnothing 2.5	\varnothing 2.5	
indexing time		sec 0.25	0.25	0.25	
rotary tool spindle speed		rpm -	(4,000)	(4,000)	
rotary tool motor(Cont/Max)		hp -	(7.3/10)	(7.3/10)	
TAILSTOCK	quill diameter	inch \varnothing 6.3	\varnothing 6.3	\varnothing 6.3	
	quill stroke	inch 6	6	6	
	spindle taper	MT MT5(Built-in)	MT5(Built-in)	MT5(Built-in)	
MACHINE	Size(with Side Chip conveyor)L×W×H	inch 185(230)×87.8×91.3	219(257)×84.7×92.9	250(28.87)×90×91.67	
	Size(with Rear Chip conveyor)L×W×H	inch -	-	-	
	weight	lbs 22,046[24,250]	28,660	44,092	
	Coolant tank capacity	Liter 351	400	600	
ELECTRIC POWER SUPPLY		kVA/V 60/220	60/220	60/220	
CONTROLLER		Fanuc Oi-TF			

• Figures in inches are converted from metric measurements.
• Design and specifications subject to change without notice.

* [] : C Type

Standard Accessories

- COOLANT SYSTEM
- BUILT-IN WORK LIGHT
- SPLASH GUARD
- HAND TOOLS
- 18 " HYDRAULIC CHUCK
- 24 " HYDRAULIC CHUCK(BB)
- SOFT JAW 3 SETS
- TOOL HOLDERS
- LEVELING BLOCK
- TOOL PRESETTER
- PROGRAMMABLE TAILSTOCK

Optional Accessories

- HARD JAW 1 SET
- CHIP CONVEYOR
- AIR BLOW UNIT
- HYD. STEADYREST