

NC Specifications / FANUC Series

Item	Description	
Controlled axes	Controlled axes	3-axis(X,Y,Z)
	Max. simultaneously controlled axes	Positioning(G00) / Linear Interpolation(G01) Circular Interpolation(G02, G03)
	Least input increment	0.001mm / 0.0001"
Spindle function	Spindle speed control	S5 (5 Digit)
	Spindle speed override	0~120%
	Spindle orientation	M19
Feed function	Feedrate override (10% increase)	0~150%
	Dwell	G04
	Reference position return	G27, G28
	Manual pulse generator	0.001/0.01/0.1mm
	Dry run	F0(Fine Feed), 25/50/100%
	Rapid traverse override	F0(Fine Feed), 25/50/100%
Tool function	Tool number command	T2 (2 Digit)
	Tool nose radius compensation	G40 ~ G42
	Tool offset pairs	128EA
	Tool geometry / wear offset	GEOMETRY & WEAR DATA
Programming function	Canned cycle	G70~G72, G74~G76
	Decimal point input	Able to input up to decimal point
	SUB program	4 phase
	Work coordinate system	G52~G59
	Max program dimension	±99999.999mm
Tape Functions	M function	M3 (3 digit)
	Input code	ISO/EIA auto recognition
	I/O interface	RS232C
	Program storage space	1280M(512kb)
	Number of stored programs	400ea
Other features	Display unit / MDI	10.4" color LCD / Soft input type MDI
	Synchronized tapping	Rigid tapping function
	Background editing	Program saving / editing during automatic operation
	Backlash compensation	Pitch error offset compensation for each axis
	Search function	Sequence / program number search
	Safety function	Emergency stop / overtravel
	Program test function	Machine Lock / Single Block
	Control function	Memory / MDI / Manual
	Mirror image	
	Run hour and parts count display	
	Custom macro	#100 ~ #199, #500 ~ #999

SMEC
SMEC America Corp.

14 West Forest Avenue Englewood, NJ 07631 USA
Office: +1 201-227-7632
Email: sales@esmecamerica.com

www.esmecamerica.com
www.youtube.com/smecmachinetoolsamerica



◆ Design and specifications subject to change without notice.

© SMEC 2019.09-NO.1

SMEC

SL 3500Y series

Y-AXIS HORIZONTAL TURNING CENTER



SMEC
SMEC America Corp.

- 1988 - Started as Samsung Heavy Industries Machine Tools Business
- 1989 - Horizontal and vertical machining center technology partnership with OKK Japan
- 1991 - Turning center and vertical machining center technology partnership with Mori Seiki
- 1996 - 5-sided processing center technology partnership with Toshiba
- 1999 - Spun out from Samsung Aerospace Industries and established SMEC Co., Ltd

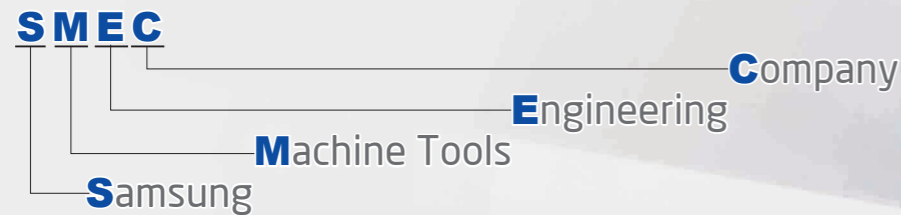

SL 3500Y/3500XY/3500LY

A Type : Chuck Size 12"

B Type : Chuck Size 15"

Strongest in class with superb structural design
 Simultaneous heavy duty and precision turning

- 30 degree torque tube type bed to support heavy duty turning
- Significantly reduced non-cutting time and efficient turning
- Low-center of gravity reducing vibration, thermal deformation and improving rigidity

High Accuracy, High Rigidity Spindle



Pin Tube Rib Design for Minimal Heat Deformation

Radiator Fan-like pin tube rib design dissipates heat generated by axis movements, maintaining minimal thermal expansion.

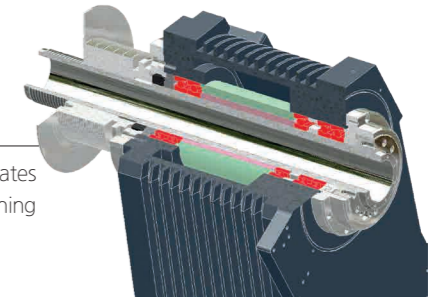

Spindle & Headstock

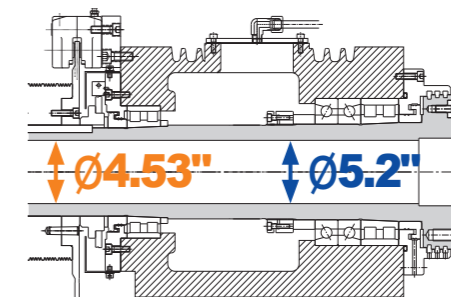

The Spindle and Headstock are machined in a temperature controlled environment and assembled in a clean room.

Spindle Speed (12" Chuck)
Max 2,500 rpm
 SL 3500Y Series (A TYPE)

Spindle Speed (15" Chuck)
Max 2,000 rpm
 SL 3500Y Series (B TYPE)

Spindle Power & Torque Diagram

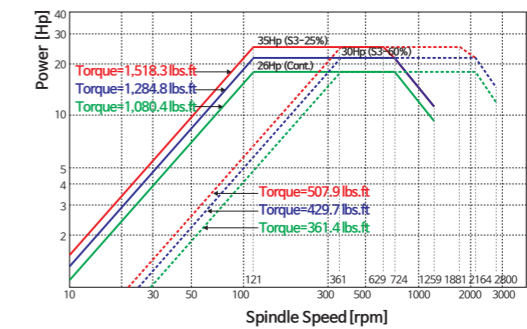

Servo Tailstock Interface

Tailstock positioning and quill thrust force are simple to set up using the specially designed servo tailstock interface.

The high speed servo driven tailstock offers high speed high precision positioning and digitally controlled thrust force settings. Quill thrust force can be set according to part length & diameter. This results in reduced down time and increased manufacturing efficiency.

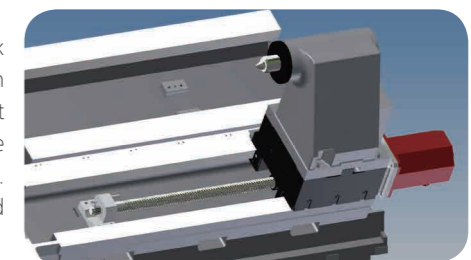

SL 3500Y/XY/LY is a heavy-duty, ultra precision Turning Center, combined with SMEC's advanced technological features.

Spindle motor(Cont./30min)
25.2/35.4 Hp

Spindle speed
2,500 rpm

Rapid traverse(X/Y/Z)
1181.1/393.1/1181.1 ipm

Max. Turning Length
31.29 inch (SL 3500Y)
60.24 inch (SL 3500XY)
83.66 inch (SL 3500LY)

Max. Turning Diameter
Ø16.93 inch

Highly Reliable and Rigid Structural Design

- One piece Meehanite casting with heavily ribbed torque tube design
- Rigid bed supports for powerful cutting
- Excellent vibration dampening and thermal displacement design

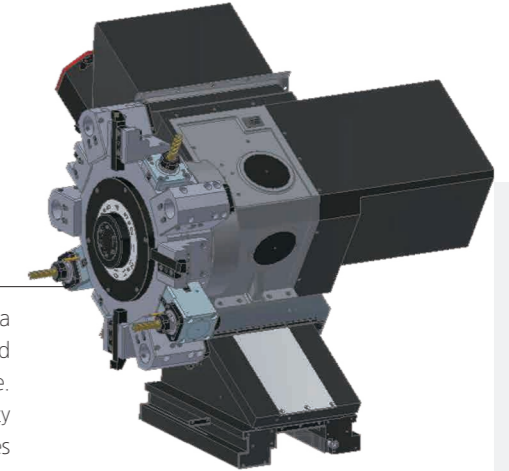

Fast Indexing and Heavy-Duty Turret Design

The 12 station heavy-duty turret features a large diameter 3-piece Curvic coupling and 7,474.5kgf(73,300N) of hydraulic clamp force. The heavy-duty design provides high rigidity for heavy cutting, unsurpassed surface finishes and long tool life.

Turret rotation, deceleration and clamp are all controlled by a reliable high torque servo motor. Turret indexing is non-stop bi-directional with a 0.15 second next station index time. Each turret station is capable of accepting both milling and turning tools.

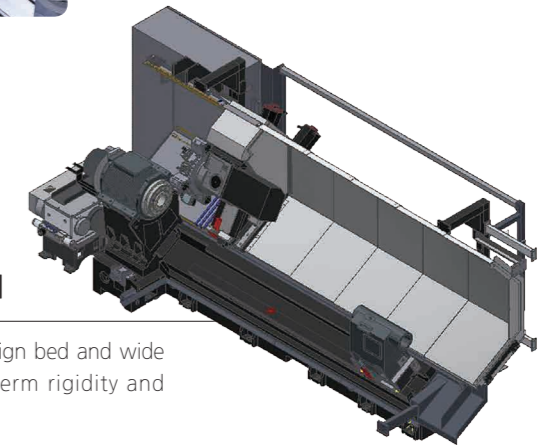
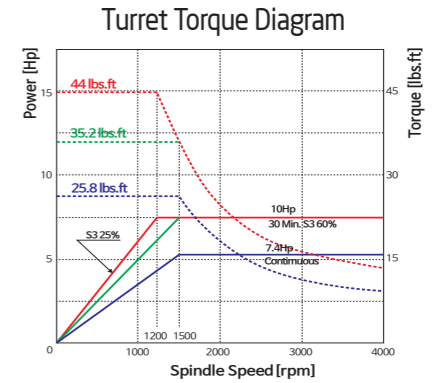
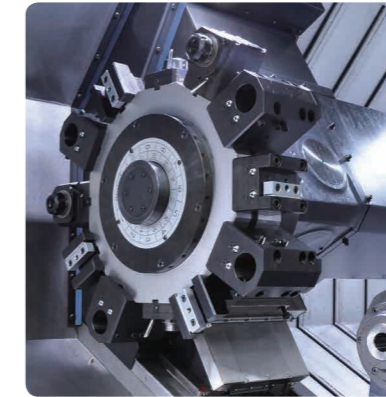

Rigid 30 degree Slant Bed

30 degree slant torque tube design bed and wide guide slide way ensure long term rigidity and machining accuracy.

Pre-tensioned and Double Anchored Ballscrews

All axes ballscrews are pre-tensioned, heat treated and fixed by double anchors on both ends, providing ultimate rigidity and minimal thermal growth.



SL 3500Y series

Y-axis Horizontal Turning center



Swivel Operation Panel

Swivel operation panel of 10.4 inch color TFT LCD monitor can turn to 81 degree, providing operators with easy access to the control panel while working on the machine.

SL 3500Y series

- SL 3500Y
- SL 3500XY
- SL 3500LY

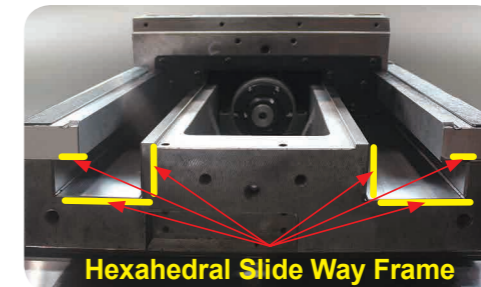

Hexahedral Slide Way Frame (X-axis)

Wide integral way is machined from the casting, induction hardened and precision ground to ensure long-term rigidity, machining accuracy and heavy-duty machining.

Y-Axis Machining

Y-axis adds integrated machining feature to a conventional turning center, providing machining capability on the workpiece that is not parallel or perpendicular to the spindle center line.

Bar machining with Y-axis control

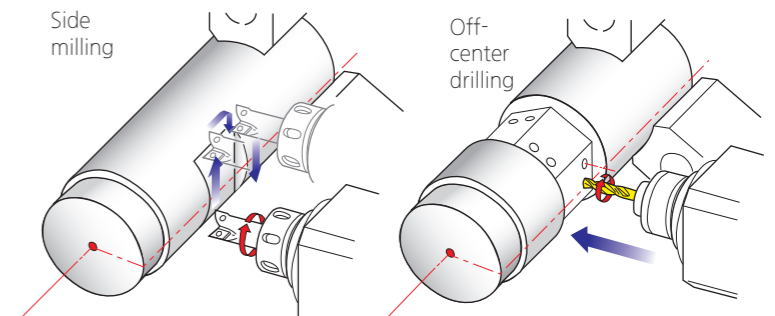

Y axis Travel
5.12(±2.56) inch

Y axis Rapid Traverse
393.1 ipm

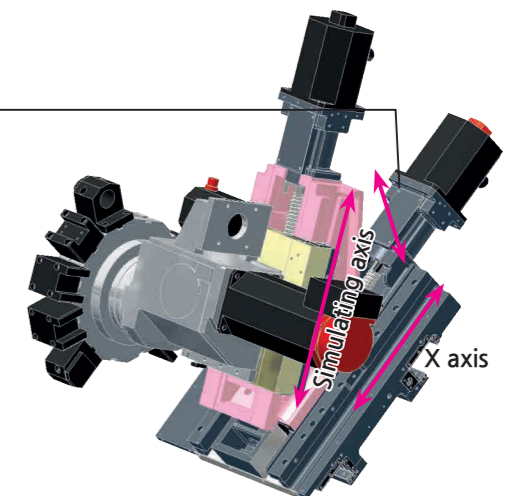

High Precision

Surface Roughness

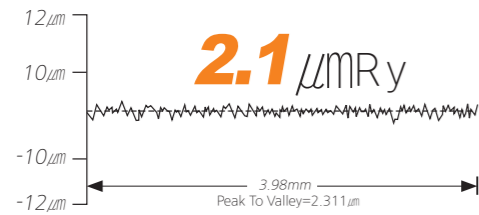

Model : SL 3500Y

Roundness

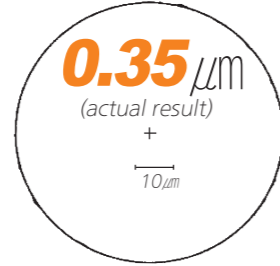

Cutting condition	
Tool	Diamond tool <nose radius 0.020 inch>
Material	AL150<Aluminum>
Cutting speed	754.6 fpm
Feedrate	0.002 ipr
Depth of cut	0.003 inch
Outer diameter	7.9 inch
Filter	1-50

Processing Speed

Turning Performance (material:SM45C) SL 3500Y

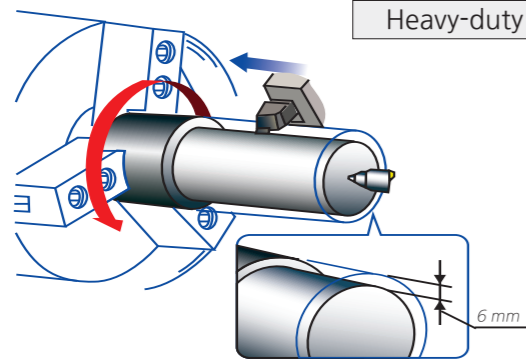

Heavy-duty cutting (O.D) <0.98inch×0.98inch qualified tool>

Spindle speed
518 rpm
Cutting speed
120m/min
Depth of cut
0.24 inch <Spindle Load 40%>
Feedrate
0.3 mm/rev

Optional Accessories



Tool Presetter

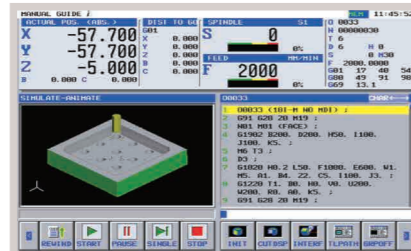

Manual Guide i

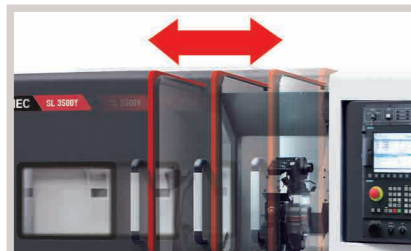

Auto Door



Chip Conveyor



Automatic Lubricator(STD.)

Tooling System

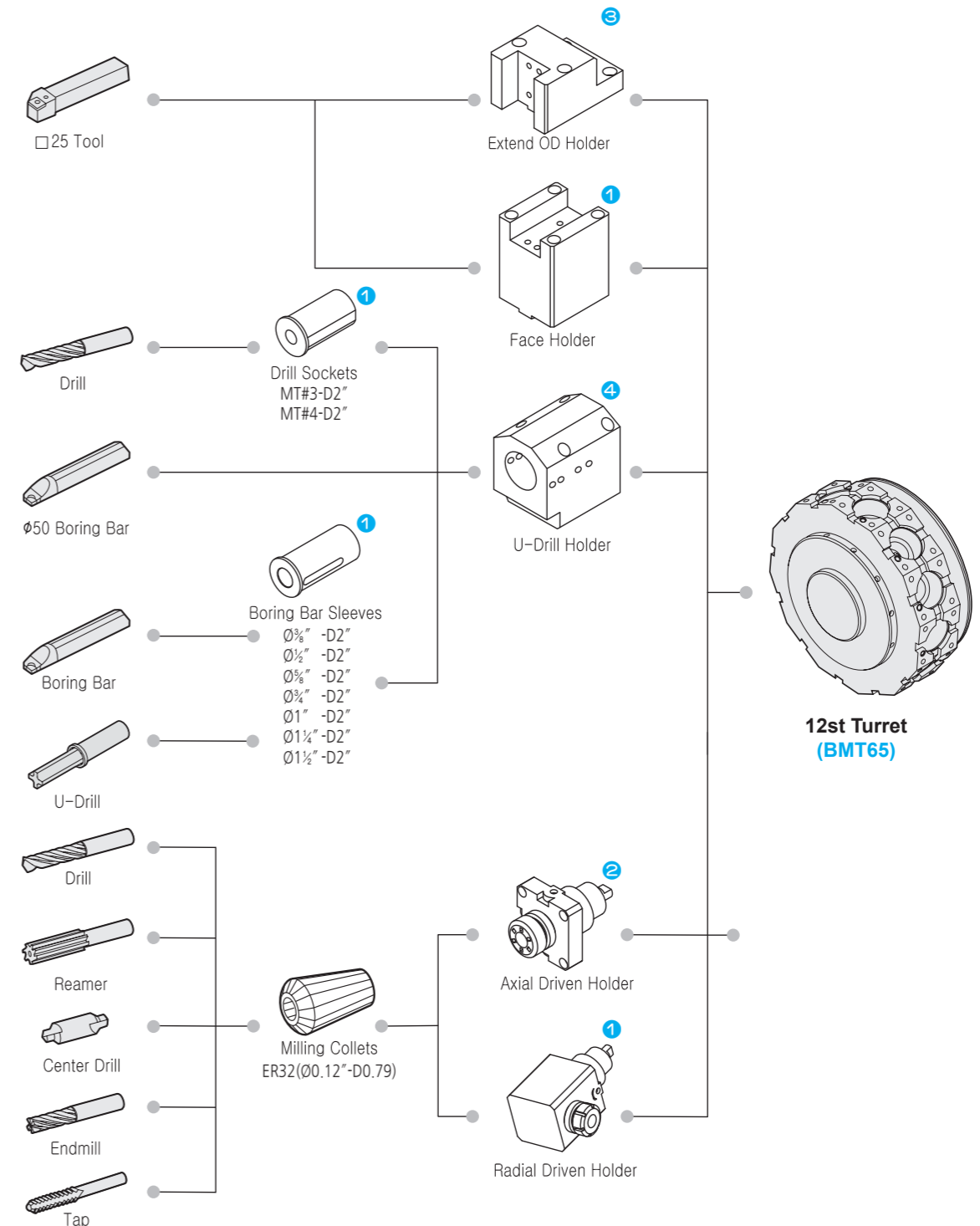

● : Standard Set Numbers

Turret Interference

Unit : inch

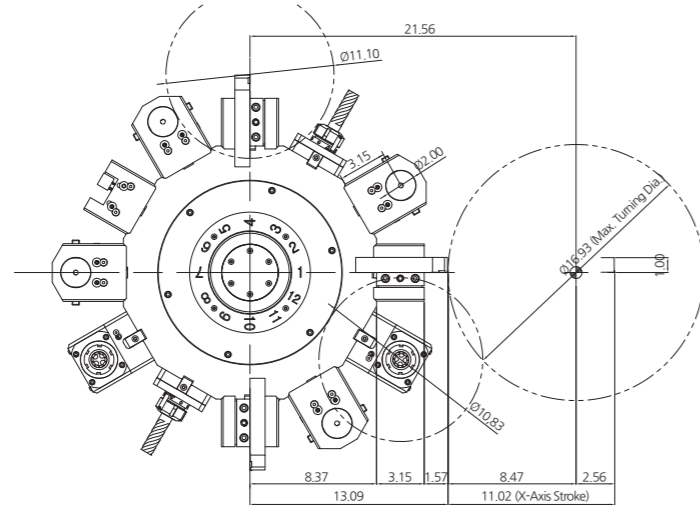

Work Range

Unit : inch

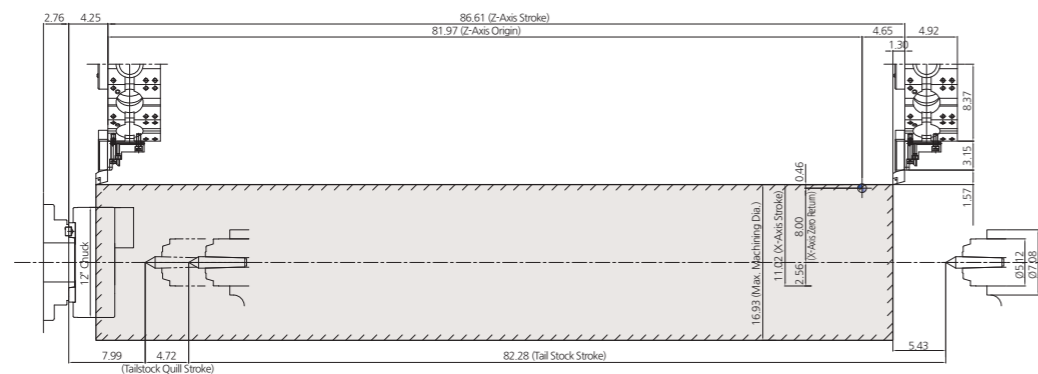

Machine Dimensions

Unit : inch

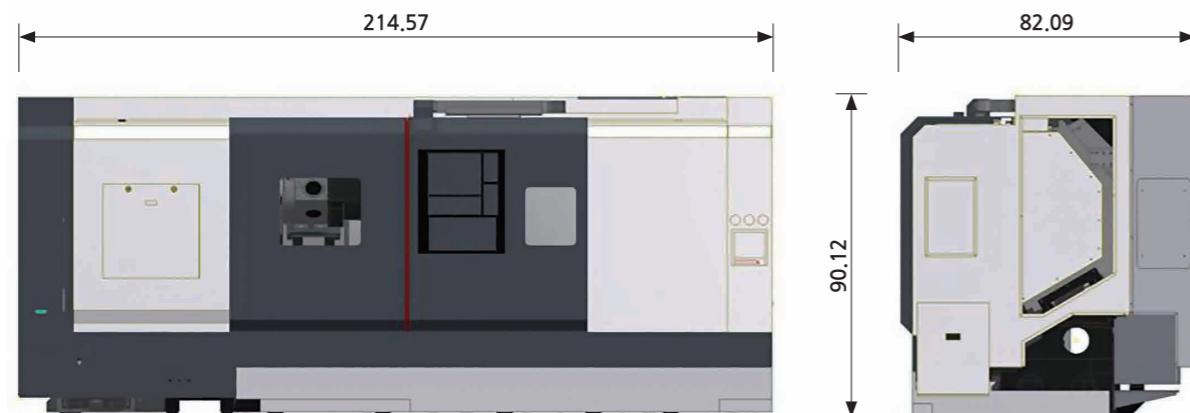

Major Specifications

DESCRIPTION		SL 3500Y	SL 3500XY	SL 3500LY
Chuck	Chuck size	inch	A Type:12", B Type:15"	A Type:12", B Type:15"
Capacity	Swing over the bed	inch	33.46	33.46
	Swing over the cross slide	inch	33.46	33.46
	Max. machining diameter	inch	16.93	16.93
	Max. machining length	inch	31.29	60.24
Main Spindle	Speed	rpm	2,500[2,000]	2,500[2,000]
	Spindle nose	ASA	A2-11	A2-11
	Bore diameter [Big bore]	inch	4.53[5.20]	4.53[5.20]
	Draw tube I.D.	inch	4.06[4.63]	4.06[4.63]
	Motor(cont./30min)	Hp	25.2/35.4	25.2/35.4
Travel	X/Y/Z axis travel	inch	11.02/5.12(±2.56)/34.05	11.02/5.12(±2.56)/63.19
	X/Y/Z rapid traverse rate	ipm	1181.1/393.1/1181.1	1181.1/393.1/1181.1
	X/Y/Z feed motor	Hp	5.4/5.4/9.5	5.4/5.4/9.5
Turret	Number of tool positions	st.	12[24]	12[24]
	Indexing time	sec	0.25	0.25
	Shank size for square tool	inch	□1	□1
	Shank diameter for boring bar	inch	Ø2	Ø2
	Live tool type	-	BMT65	BMT65
	Live tool speed	rpm	4,500	4,500
	Milling motor (cont./30min)	Hp	7.5/10.2	7.5/10.2
ELECTRIC POWER SUPPLY		kVA/V	50/220	50/220
REQUIRED FLOOR SPACE(L×W×H)		inch	157.8×85.1×90.12	183.86×82.09×90.12
MACHINE WEIGHT		lbs	15,432	19,180
CONTROLLER			Fanuc Oi Series	

*Design and specifications subject to change without notice.

[] : B Type

Standard Accessories

- 10.4" TFT LCD Color Monitor
- Work Light (Led lamp)
- Coolant System (4.5bar/60Hz)
- Splash Guarding (Full Coverage)
- Programmable Tailstock
- 12" Hydraulic Thru-hole Chuck
- Hydraulic Unit
- Lubrication System
- Chuck Foot Switch
- Front Door Interlock
- Machine Arranged for 220V±10%, 60Hz
- Foundation Kit (Plates Only)
- Soft Jaws

Optional Accessories

- Auto Door
- Double Foot Switch
- Tool Pre-Setting System (Tool Presetter)
- 3 Step Patrol Lamp
- High Pressure Coolant
- Chip Conveyor
- Chip Bucket
- Chuck Air Blower
- 15" Hydraulic Chuck
- Hyd. Steady Rest
- Oil Skimmer
- Coolant Gun
- Transformer (380/400V Internal)
- Holder & Sleeve etc.
- Hard Jaws