



ZEISS CT Solutions

Computed Tomography for Quality Assurance
and Process Inspection



Table of Contents

| | |
|---|-----------|
| Introduction: ZEISS CT Technology | 6 |
| Application Examples | 10 |
| CT Technology in the Industrial Process | 14 |
| Technical Design | 16 |
| ZEISS METROTOM | 20 |
| ZEISS VoluMax | 24 |
| Software | 28 |
| After Sales Services | 32 |
| CT Inspection Services | 34 |

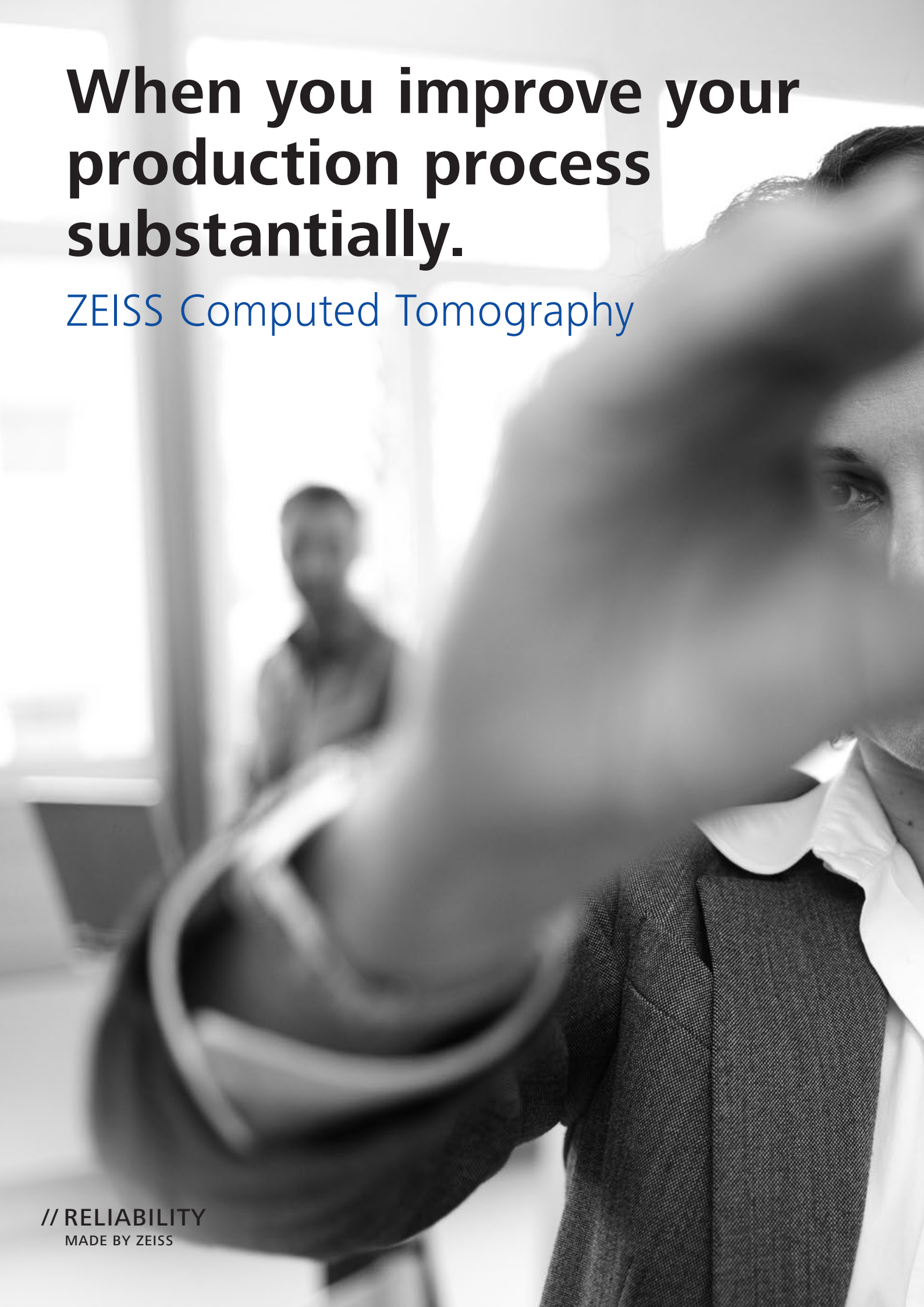

**When you improve your
production process
substantially.**

ZEISS Computed Tomography

// RELIABILITY
MADE BY ZEISS



X-ray eyes for greater efficiency and transparency in the entire industrial process – and all in 3D

Industrial computed tomography (CT) gives you entirely new insights by making it possible to capture the volume of all internal structures in next to no time. ZEISS is a pioneer in fast CT and enables the complete volume-based inspection of components during the production cycle.



115,5183

The image shows a 3D CT scan of a mechanical component, likely a turbine or engine part, with a complex internal structure. The scan reveals numerous small, dark blue spots scattered throughout the volume, representing defects or inclusions. A prominent red, irregularly shaped defect is highlighted in the lower-left quadrant. Other smaller defects are highlighted in green and orange. A blue arrow points from a green box containing the number '115,5183' to the red defect. The component is shown in a semi-transparent, greyish-white color, allowing the internal features to be clearly visible.

Ø 25,5428



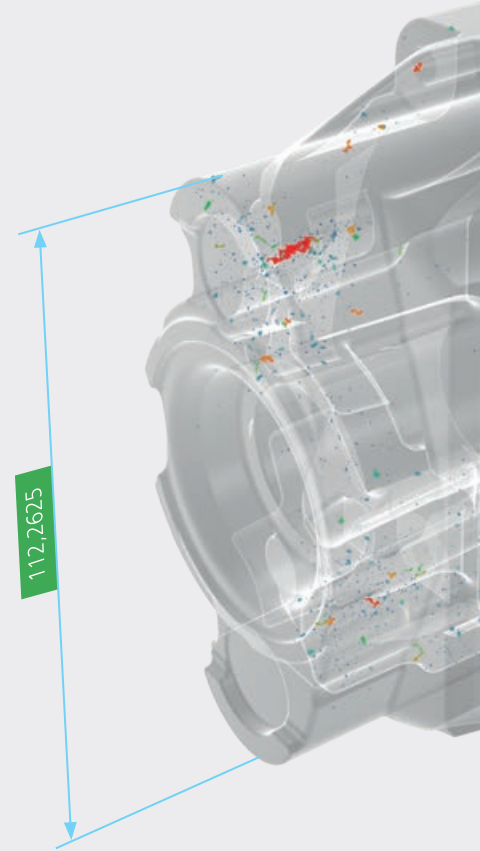
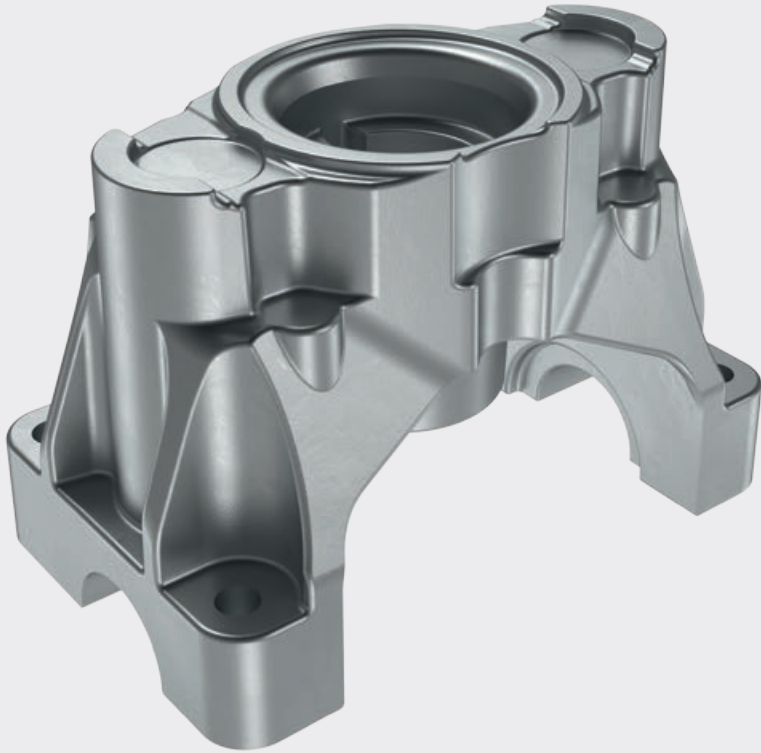

Metrological inspection and porosity analysis of a light metal component

Technology for Industry 4.0

Industry 4.0 refers to a fundamental shift in industrial production methods where increasingly more data are captured, networked and evaluated together. Computed tomography is one engine driving this development. Only with the current generation of high-performance computer and network technology has it been possible to process the data quantities generated by computed tomography. These data provide an enormous amount of information. A ZEISS CT machine delivers a three-dimensional data model for a complete component in record time. It

can be used for numerous evaluations which would otherwise require multiple lengthy inspections. Linking CT data with other quality and production data also offers opportunities for improvement along the entire process chain.

Complete and highly efficient measurements

ZEISS CT technology delivers highly precise measurement analyses of complete components. It is also possible to measure characteristics which are covered, difficult to reach or are hidden without destroying the component. Complicated fixtures are no longer needed. And

because only one scan is necessary to completely capture a component, a significant amount of time is saved on contact and optical measuring processes, such as when creating initial sample test reports. With smaller components, it is possible to scan multiple components once and evaluate them separately.

Typically ZEISS: reliable precision

The expertise from Industrial Metrology is reflected in the highly precise measurements and repeatability of ZEISS CT machines. All components, including the travel axes, X-ray tube and detector,

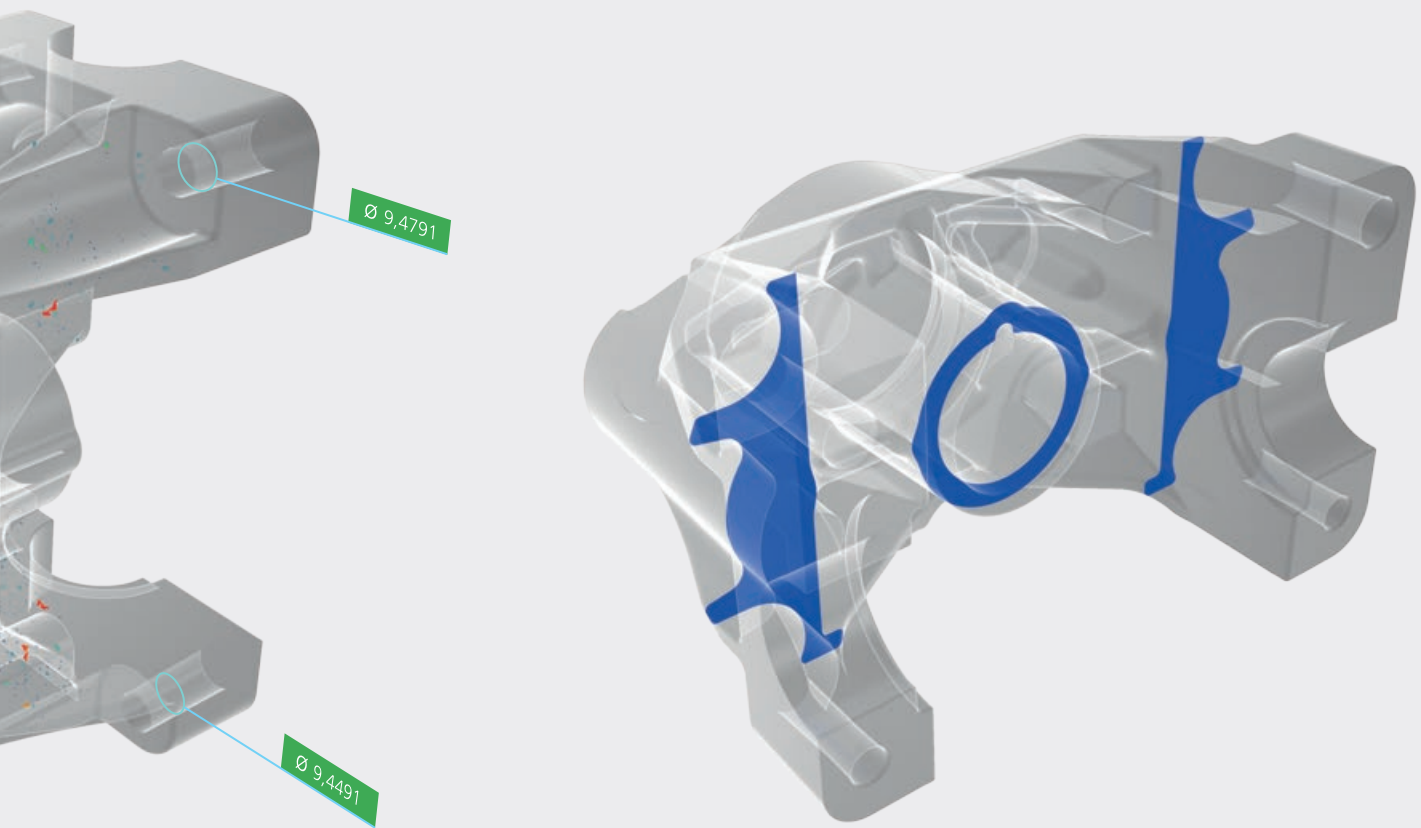

CT technology enables the destruction-free sectioning and inspection of a component

are designed to ensure accuracy, and the measurement results are traceable to the national German standard.

Evaluating with the leading tried-and-tested software

ZEISS CALYPSO and ZEISS CALIGO software offer the same measuring evaluation software available for ZEISS coordinate measuring machines. This makes programming easy for operators already familiar with the software. Existing measuring programs can be transferred for evaluation without changing them, ensuring the best possible comparability of the results.

Consistency is a way of life at ZEISS. In order to offer you viable solutions for every application, ZEISS is your one-stop shop for hardware, software and service.

Inspect, Measure and Test in Production

Application examples for ZEISS CT technology

Increasingly shorter component life-cycles and consequently increasingly shorter development times are currently the trend in industry. On top of this, components have increasingly elaborate surface shapes and more complex structures which must be manufactured and tested appropriately. Industrial computed tomography rises to the challenge by delivering maximum information in the shortest amount of time.

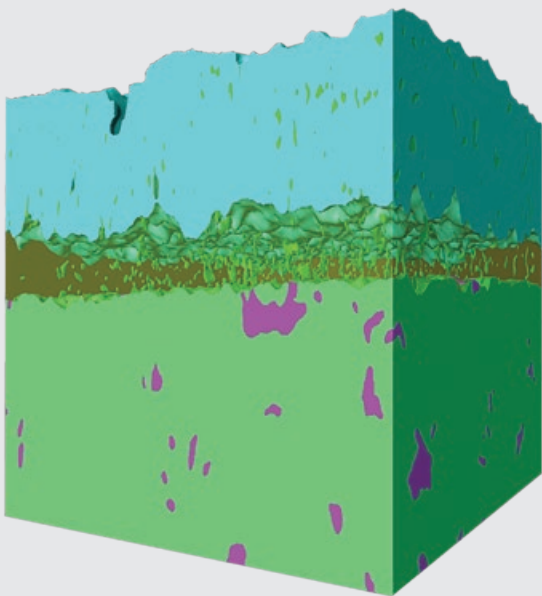

Fiber structure of a polymer compound material

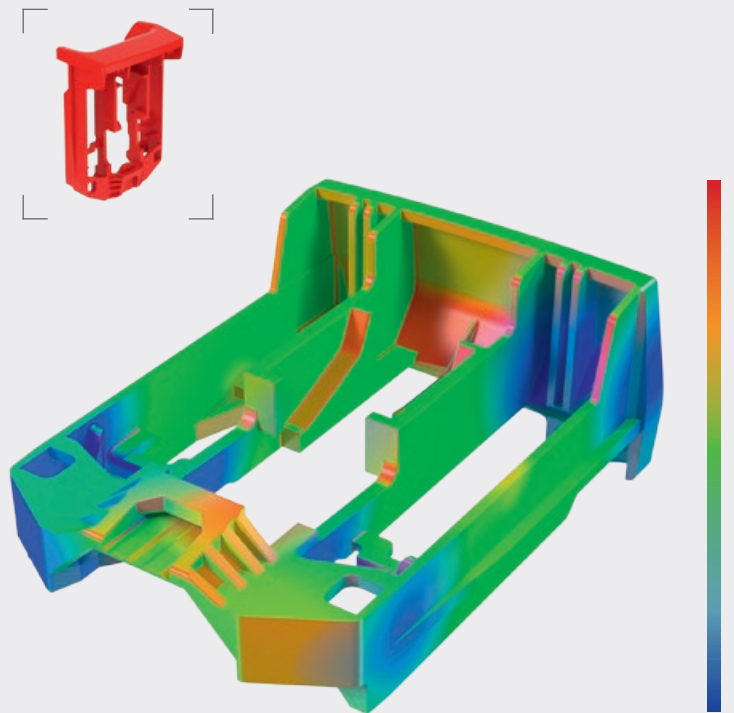

The button for a seat belt buckle in a car

Visualizing microstructures in 3D

ZEISS X-ray Microscopy visualizes material distributions, cavities and tears in microscopic 3D resolution. Thanks to this technology, composite and sintered materials as well as ceramics can be checked and geological and biological specimens can be analyzed.

Complete testing of dimensional specifications is easy

Using CT technology, it is quick to ascertain whether or not nominal specifications have been met and where a component deviates from the target – all without needing to create a measuring program. Oversize and undersize are marked in color, making it quick to capture them. The same technology can be used to check a random sample against initial samples.

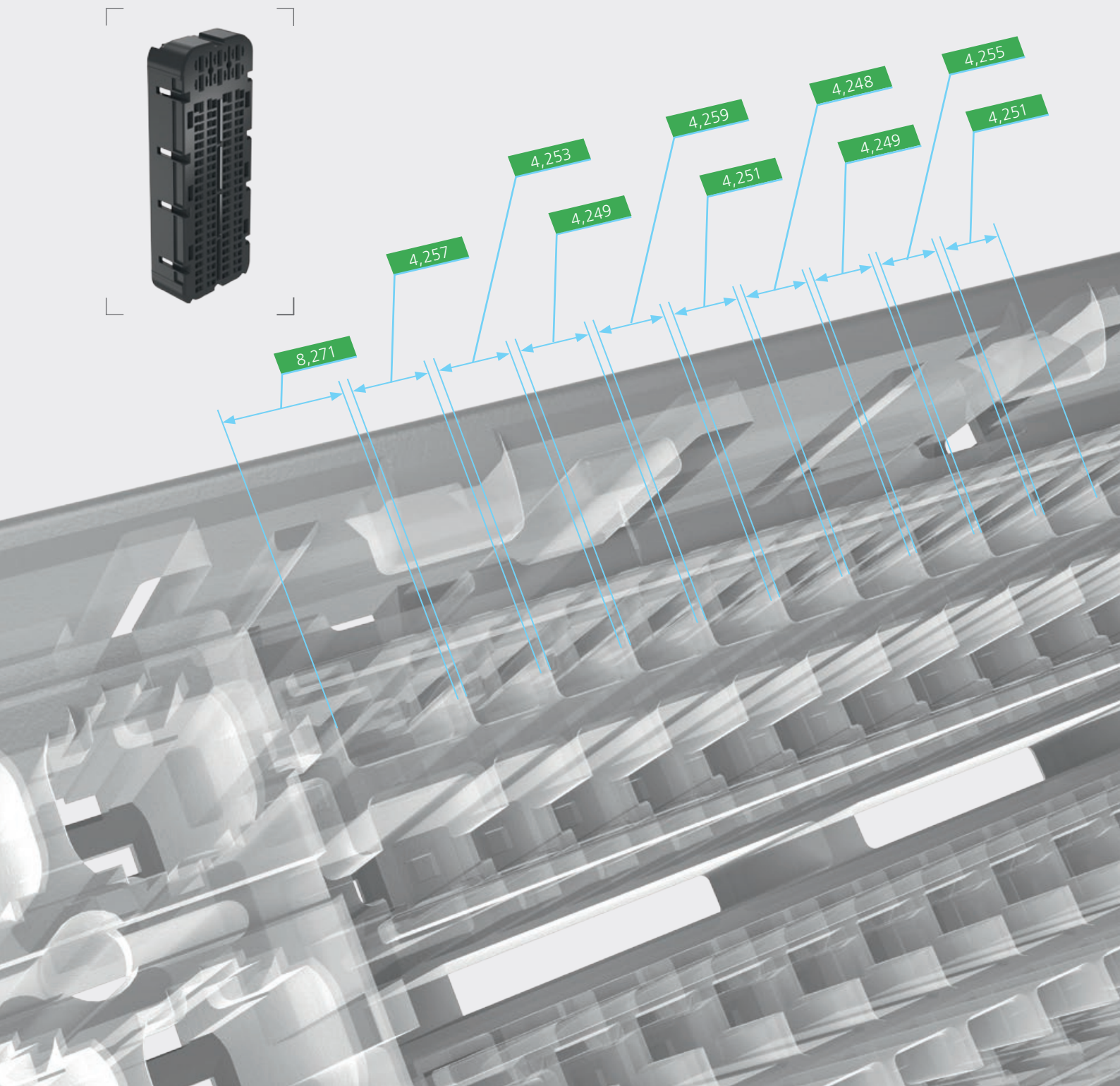

Measurement of a base plug

Measure a lot of characteristics easily and precisely

With ZEISS CT technology, numerous component characteristics are scanned in one run. The resulting measurements are precise and traceable. Unlike contact measuring methods, ZEISS CT technology is significantly faster when capturing numerous measuring points.

And in comparison to optical measuring methods, covered or hidden structures can also be measured accurately and easily by using this technology.

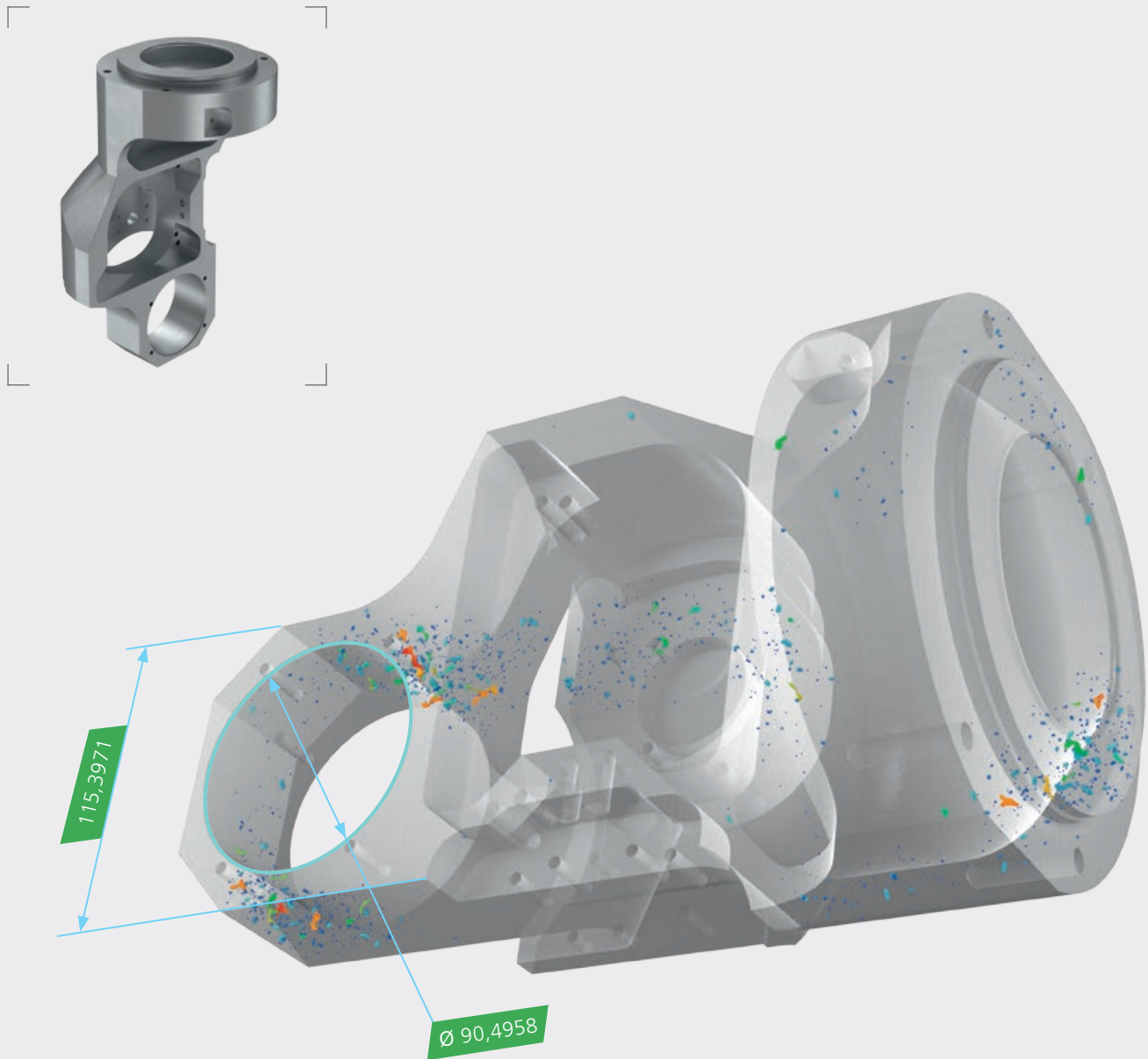

Analysis of a medical housing made of metal for dimensional stability and cavities

Perform all testing directly in production

ZEISS in-line CT machines perform 100% of all inspections on manufactured plastic and light metal components in the production flow – even in harsh production environments. They automatically provide good/bad evaluations so that unusable components can be filtered out. Many different product features can be captured and saved during CT serial inspection. Important

statistical parameters can be derived and visualized using these data – providing a valuable knowledge base for optimizing manufacturing processes and production quality.

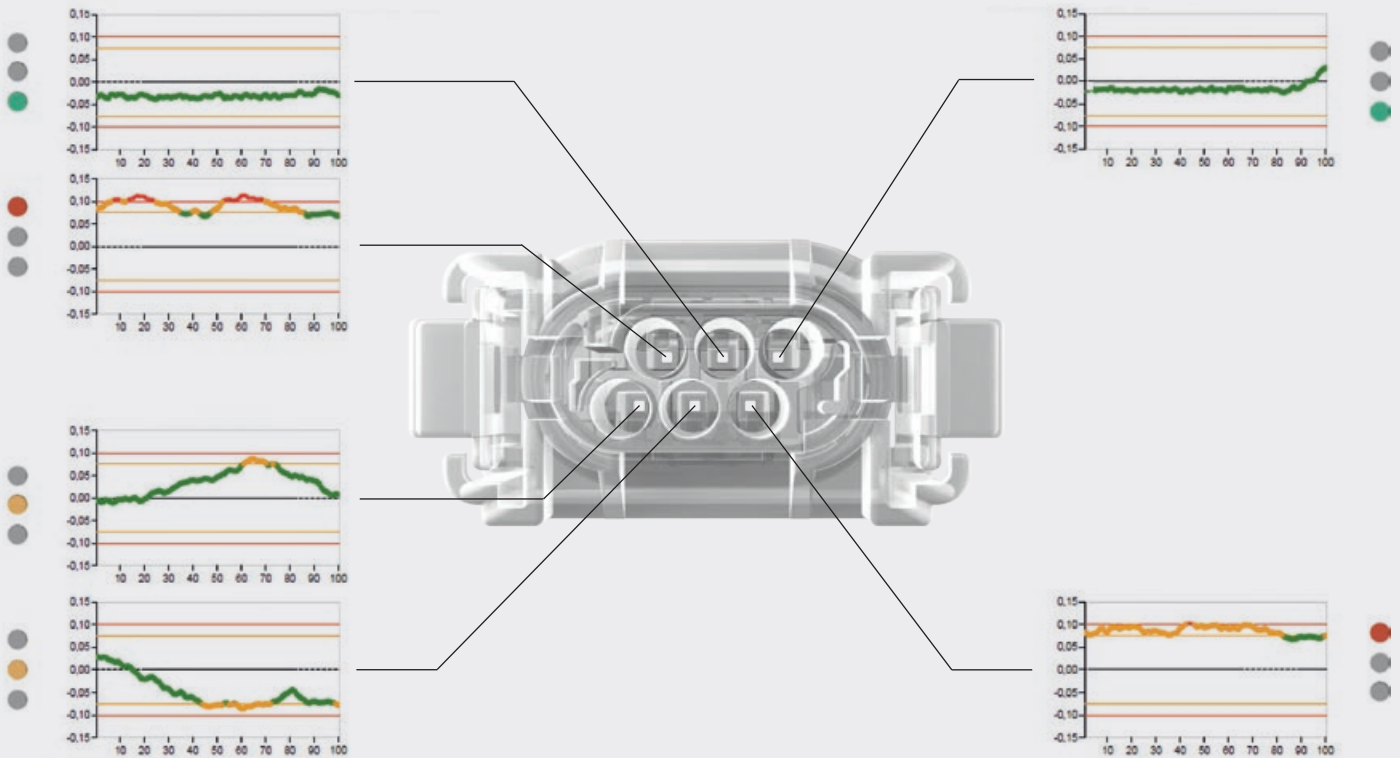

CT results can be used decentrally with ZEISS PiWeb data management software.

Statistical evaluations

CT serial measurements in production provide the data sequences so that value curves can be displayed graphically or evaluated statistically using the ZEISS PiWeb quality data system. The graphics show you at a glance when and where quality problems have occurred. Gradual deterioration in quality can be recognized early. ZEISS PiWeb also delivers statistical evaluations from the C_p and C_{pk} process capability indices so that the production quality can be evaluated and documented in its entirety.

Checking measuring system analysis

By using the ZEISS PiWeb quality data system, highly precise measuring results from the measuring lab can be aligned with the results from a ZEISS in-line CT in production. This way measuring system analysis in production can be performed reliably and efficiently.

Identifying and controlling quality factors

The evaluation possibilities increase substantially when additional production parameters are captured using ZEISS PiWeb. What influence does the batch of raw material have on the quality? What effect does the temperature of the hall have on production? What effect do the parameters for the tool machines have e.g. on pressure, temperature or voltage? With ZEISS PiWeb it is easy to capture these data and examine them for possible correlations with quality-relevant characteristics.

Using ZEISS CT-Technology in the industrial Process

General research

Product- and process development



ZEISS Xradia X-ray microscopes

ZEISS METROTOM Computer tomograph

| | |
|-----------------------------|---|
| Application | High-resolution detail analysis |
| Particular strenghts | Resolution in the submicron an nano range |
| Place of use | Lab |
| Resolution | Under 700 nm (Versa), 50 nm (Ultra) |
| Speed | Hours |

| |
|---|
| Measuring and evaluating entire components |
| Standard-compliant and traceable precision |
| Testing as per VDI/VDE 2630, Evaluation with ZEISS CALYPSO |
| Measuring lab |
| 3,5–6 µm |
| Minutes |

Parts manufacturing, Assembly in volume production

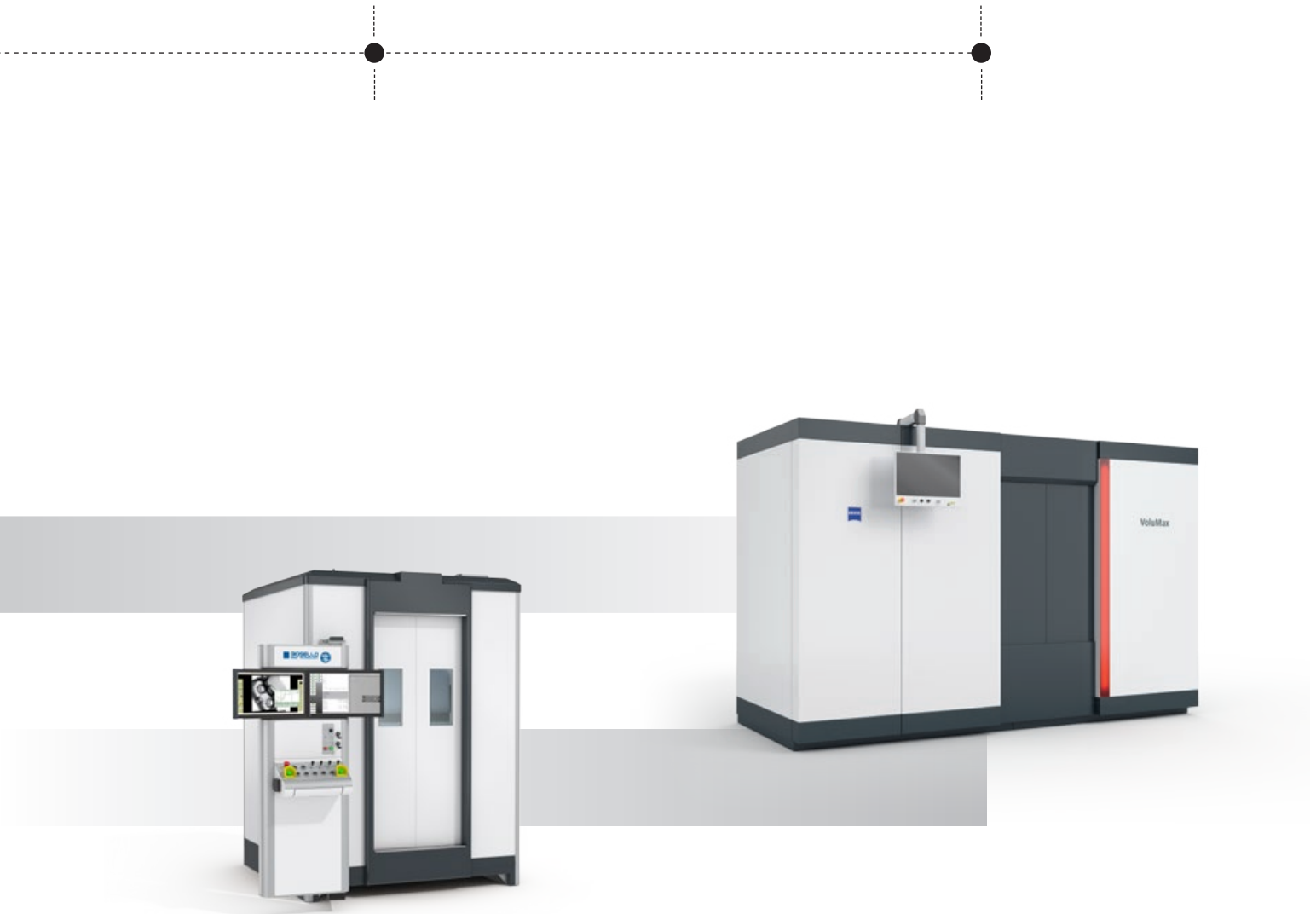

SRE MAX from Bosello a company of the ZEISS group

Inspection with high throughput, 2D
 Customized product design,
 2D Radioscopie with easy handling
 comprehensive project experience
 In production und near production
 100 - 400 μm
 Seconds

ZEISS VoluMax Computer tomographs

Inspection with high throughput
 Customized product design,
 Inline & Atline Computertomograph
 comprehensive project experience
 In production und near production
 3,5-400 μm
 Seconds

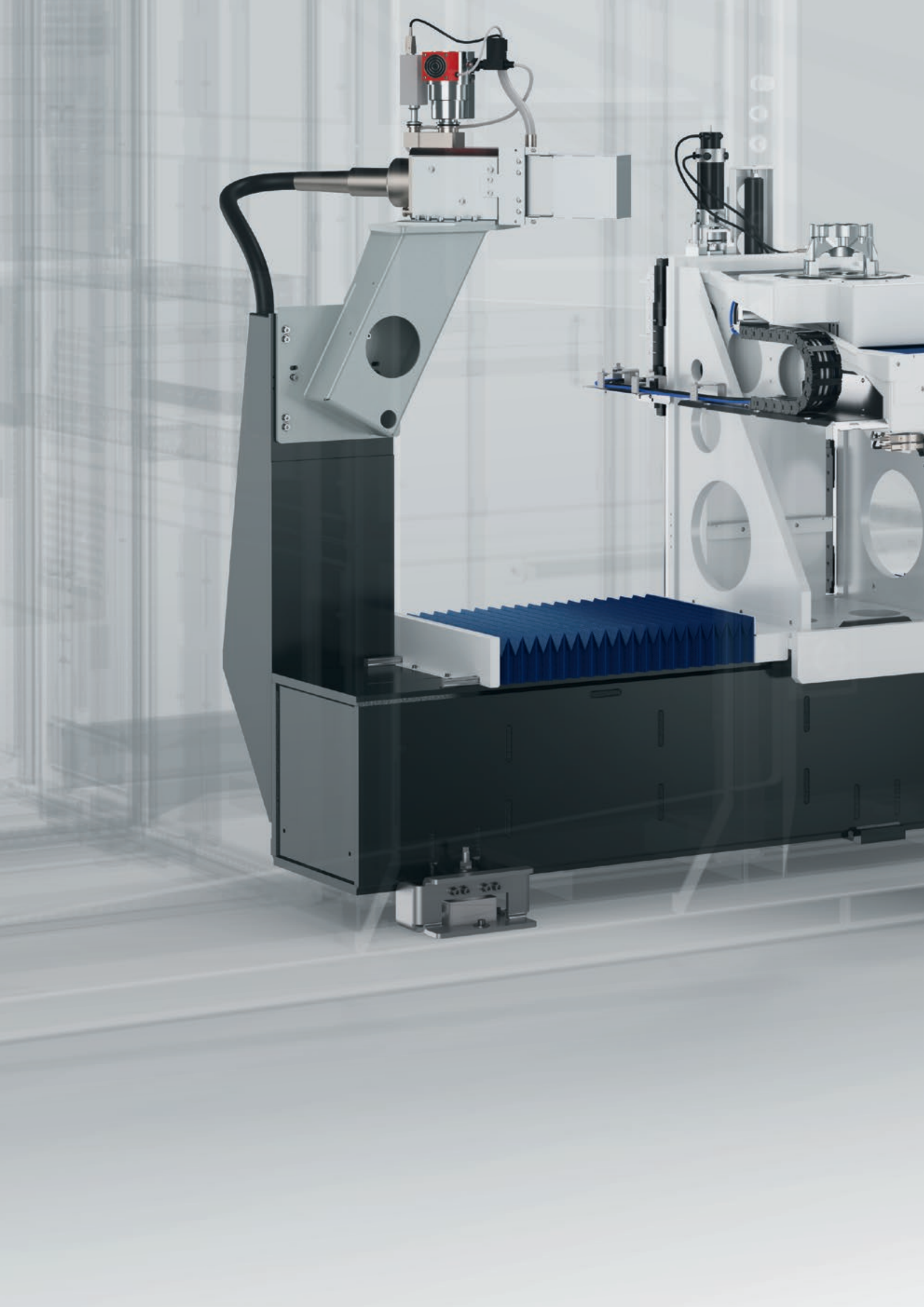

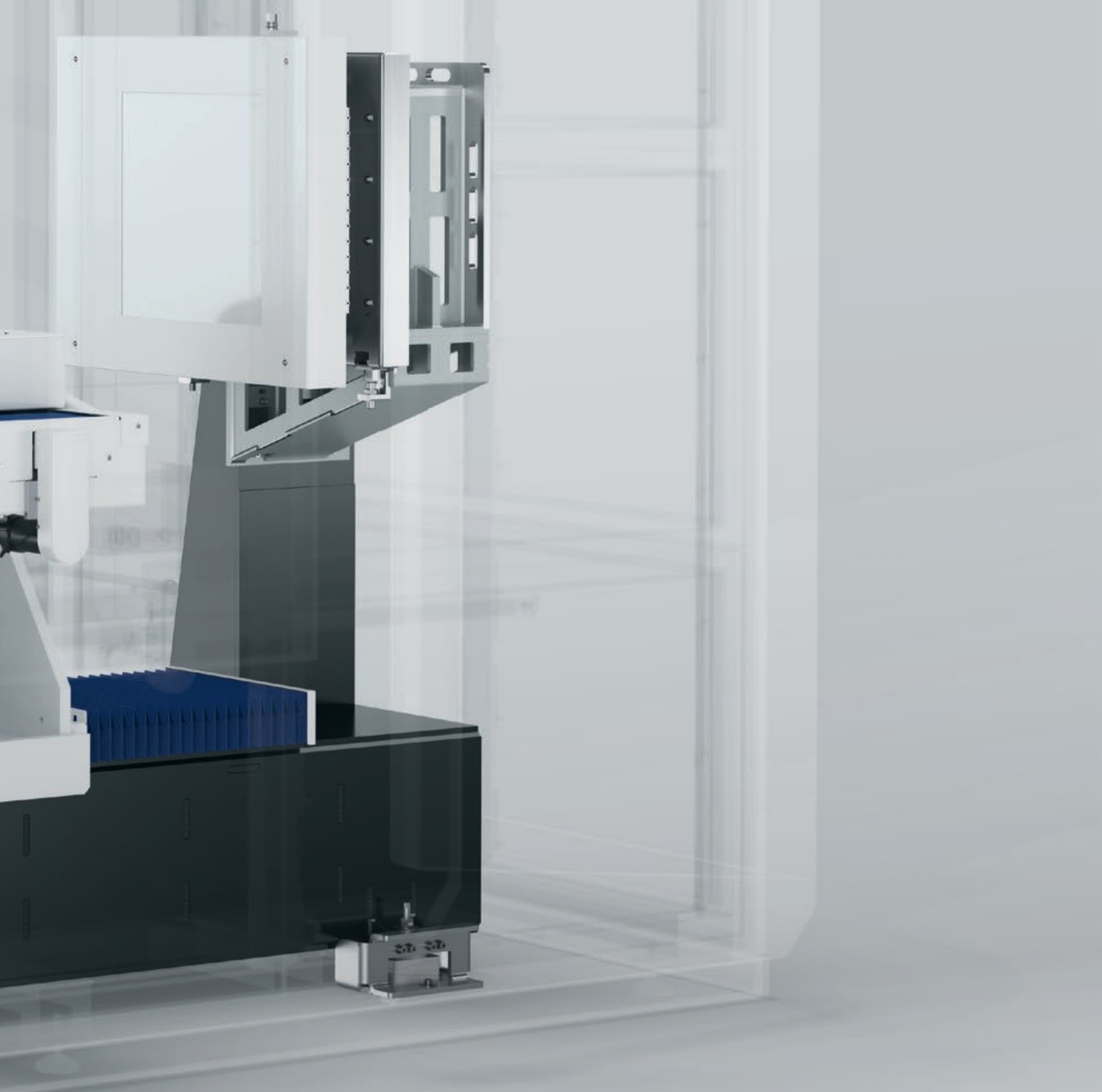

ZEISS CT Technology

A customized combination of selected components

ZEISS METROTOM and ZEISS VoluMax CT machines are constructed following the same tried-and-tested principle. These systems have a cone-shaped beam path and flat image detector. The highly precise travel axes for positioning and rotating the workpiece ensure excellent repeatability. Different designs are available for the tube, axes and detector. These can be combined to meet each customer's particular requirements.

Tube/detector distance

The distance between the tube and detector determines the available measuring range. Within this measuring range, components can be tomographed with just one scan. 400, 800 and 1,500 mm are available.

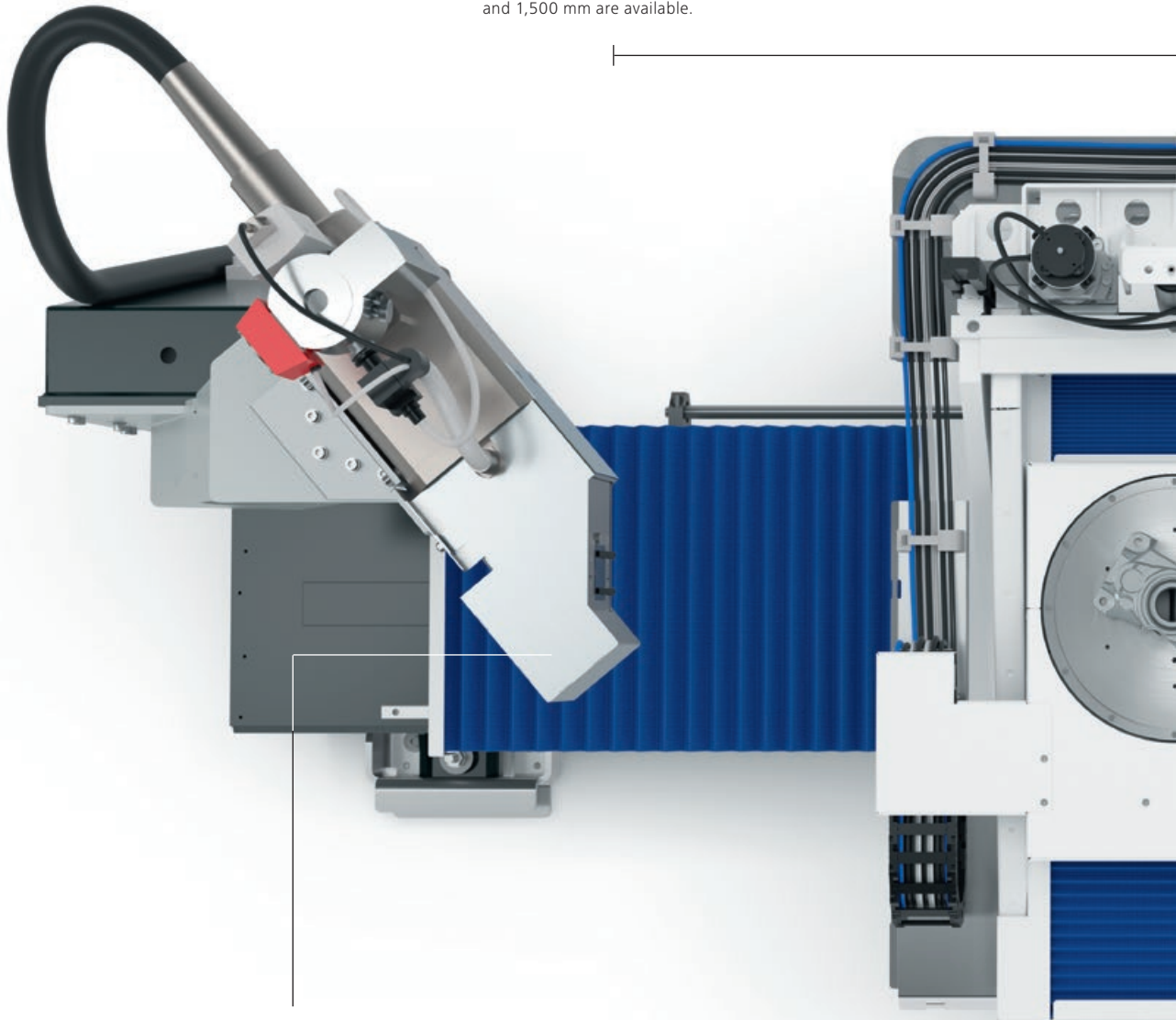

X-ray tube

The X-ray tube used determines the range of applications: a smaller focal spot for high resolution, a high tube power for quick scans and a multifocus tube for diversity in application.

CT inspection process: tomography, reconstruction, evaluation

The inspection process with a ZEISS computer tomograph is divided into three phases. The first step is X-raying the component. The component rotates on a precision rotary table in order to project individual 2D X-ray images suc-

cessively onto the detector shield. The second step is volume reconstruction: a computer merges the 2D X-ray images to create a 3D volume model. At this point, the component can already be analyzed optically in 3D. The third step is evaluation and visualization: a suitable 3D data model is generated in order

to perform inspection jobs or to create informative 3D visualizations.

Highly precise and fast

With every computer tomograph there is a physical correlation between the power of the X-ray tube, the imaging precision and the necessary irradiation

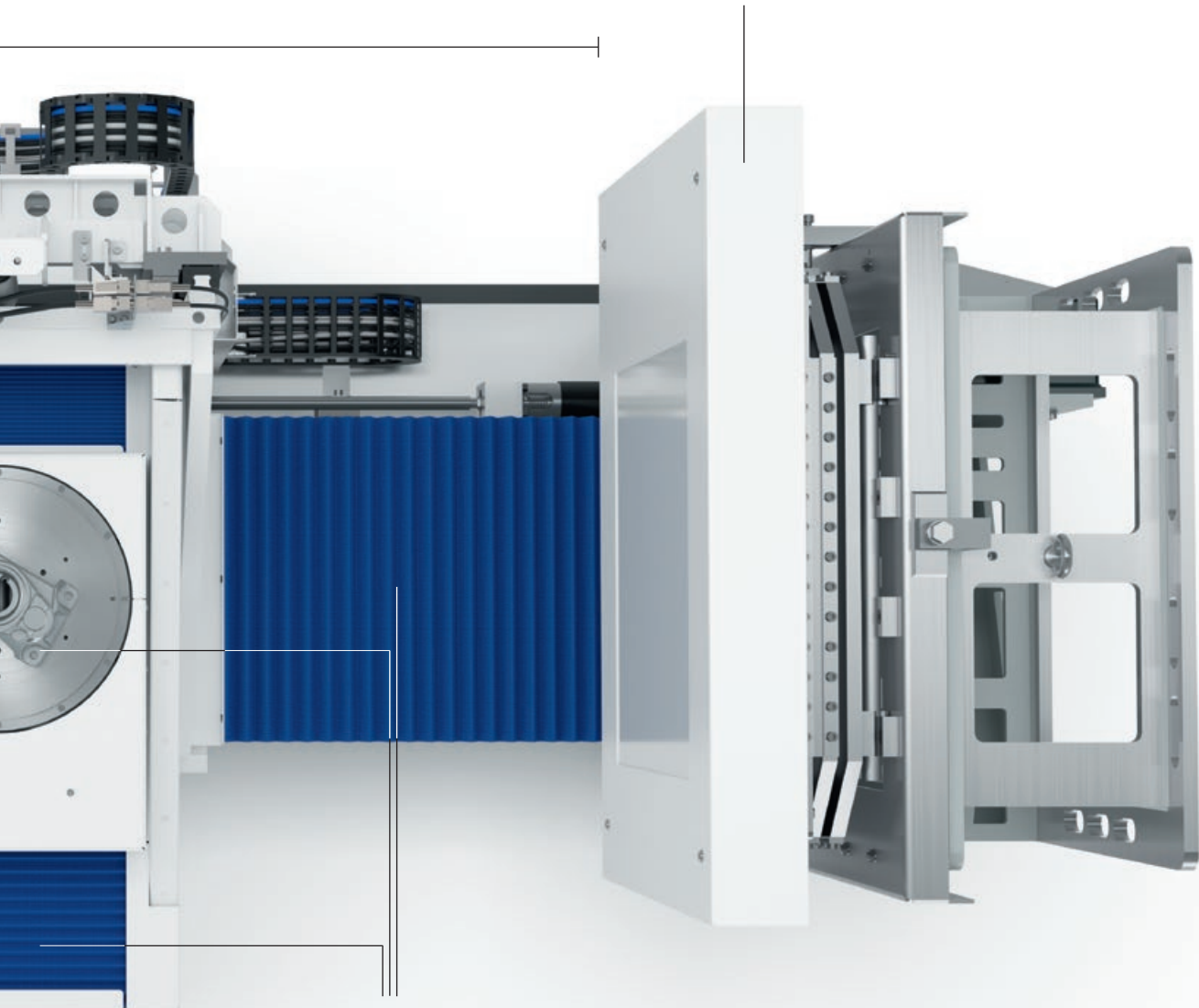

Flat image detector

High-resolution applications require a high-resolution detector. For high-speed applications, detectors with high frame rates are used.

Precision axes

The workpiece can be moved with extreme precision on four axes. ZEISS relies on precision axes from coordinate measuring technology and turns the computer tomograph into a measuring machine.

period. Reducing the power creates a clear focal spot and thus enables sharper imaging. The irradiation period must be increased in order to obtain sufficient image information. This is comparable with taking a photograph where the exposure time is increased because of reduced ambient brightness. ZEISS

offers you the right system tailored to your job with perfectly coordinated components – from ultra precise to extremely fast.



ZEISS

METROM

Traceable 3D X-Ray Measurements

ZEISS METROTOM

With a ZEISS METROTOM computer tomograph, you can successfully perform measuring and inspection jobs yourself with only one X-ray scan. The standard acceptance test, the precision engineering and the sophisticated calibration process ensure the traceability of the system. Linear guideways and a rotary table meet customers' highest demands for precision. The ZEISS CALYPSO reference software is available for metrological evaluation.

Easily measuring the unseen

The ZEISS METROTOM is an industrial computer tomograph for measuring and inspecting complete components made of plastic or light metal. With traditional measuring technology, hidden structures can only be inspected after the time-consuming process of destroying the component layer-by-layer. With the ZEISS METROTOM, it is easy to see and evaluate hidden structures and there is no need to perform any intricate clamping.

ZEISS METROTOM OS – user-friendly and powerful

Following a short training course on how to use the ZEISS METROTOM OS machine software, the operator is able to tomograph components and look into the interior of the component. The software also offers experienced operators many filter and artifact reduction functions. The tomograph data generated can be used for different evaluations or 3D visualizations.

Metrological evaluations with ZEISS CALYPSO

With ZEISS CALYPSO, the leading software in coordinate measuring technology is available for metrological evaluations. Just as with the measurement data from a ZEISS bridge-type measuring machine, professional analyses of size, form and position are possible

without any constraints. Experienced ZEISS CALYPSO users follow a familiar procedure to immediately evaluate METROTOM data. Measurement plans written for bridge-type measuring machines can be used one-to-one for the METROTOM data. The results are directly comparable.

Volume visualization and analysis with ZEISS

You can use CT visualization software from ZEISS or programs from third-party providers to evaluate and inspect the volume data from the ZEISS METROTOM in 3D. Use ZEISS visualization software e.g. to capture the spatial distribution of pores in a component at a glance or to detect hidden defects in the interior.

X-ray once, evaluate anytime

Whenever a ZEISS METROTOM volume dataset is archived, the operator can still access it years later and perform evaluations. For example: if a product is returned, an inspection can be performed to see whether or not a defective component already had defects at the time of delivery which could have caused the defect.

Reliable measurements without any detours

The ZEISS METROTOM has a specified, traceable measuring accuracy as per VDI/VDE 2630 and is calibrated

using a patented process. Additional calibrations using limit gages or reference measurements with additional sensors are not necessary. With the ZEISS METROTOM, your measurements will be straightforward, fast and reliable.

Metrological competence in all components

Reliable linear guide and bearing technology like that used in other ZEISS coordinate measuring machines ensures maximum precision and repeatability with the ZEISS METROTOM. All travel axes are also CAA corrected, meaning that the measurements of the longitudinal and rotational axes are highly accurate. Any deviations from the ideal axis are considered in the 3D volume calculation.

The tube and the detector X-ray components are specially optimized for metrological applications. During the measurement, the position of the focal spot is captured using the tubes to compensate for any deviations. Minute position deviations for the individual pixels are captured and corrected with the detector.

ZEISS METROTOM 800

ZEISS METROTOM 800 HR



| | | |
|---------------------------------|-------------------------|-----------------------|
| Tube voltage, tube power | 130 kV, 39 W | 225 kV, 500 W |
| Tube type | Closed micro-focus tube | Open X-ray technology |
| Source/detector distance | 800 mm | 800 mm |
| Measuring range | Ø 150 mm x 170 mm | Ø 170 mm x 150 mm |
| HR Version | | Ø 170 mm x 115 mm |
| Detector resolution | 1536 x 1920 Px | 1024 x 1024 Px |
| HR Version | | 1536 x 1920 Px |
| Enclosure material | Polymer concrete | Lead |

ZEISS METROTOM 1500



| | |
|---------------------------------|-----------------------|
| Tube voltage, tube power | 225 kV, 500 W |
| Tube type | Open X-ray technology |
| Source/detector distance | 1500 mm |
| Measuring range | Ø 350 mm x 300 mm |
| Detector resolution | 2048 x 2048 Px |
| Enclosure material | Lead |



CT Inspection with High Throughput

ZEISS VoluMax

ZEISS VoluMax CT machines are designed for applications where many components must be inspected quickly. ZEISS customizes the machine and software to fit the inspection job. The ZEISS VoluMax can be configured for both manual and automated loading.

Significant project experience

Many projects for the CT inspection of plastic, metal and composite components have already been implemented using the ZEISS VoluMax systems. For example: ZEISS VoluMax machines have inspected the dimensional stability of plastic components, examined cylinder heads for cavities and sand residue and have been used to test whether or not an airbag has been correctly assembled. ZEISS VoluMax CT solutions are also used in-line for 100% inspection and at-line for testing large quantities of random samples.

More information: 3D vs. 2D

Unlike 2D ultrasound or 2D radiography, it is possible not only to detect a defect in the interior of the component by using the ZEISS VoluMax, but also to identify its location and severity. The severity of a defect can be assessed reliably in the 3D model, making defects easier to identify with the ZEISS VoluMax and avoiding false rejects. For example: aluminum die-cast parts with pores on machined edges can be filtered out so that no time or effort is wasted in further processing. If the pores are located on non-critical positions in the component, then the component does not need to be filtered out.

One ZEISS VoluMax scan for all characteristics

An important advantage of 3D tomography is its ability to replace multiple, complex individual inspections. Dimensional variations, discontinuities, inclusions and every type of deformation can be inspected with just one scan. Cycle times of just a few seconds are possible. Other typical inspection processes, e.g. manual gage testing, flow control or 2D X-ray scans, are less reliable and often require far more time and labor. There's an additional benefit: the results are automatically documented with the ZEISS VoluMax.

Process inspection with ZEISS PiWeb

The production process can be further improved by making CT results available and processing them further using the ZEISS PiWeb quality data system. The development of pore sizes and wall thicknesses can be analyzed chronologically. Statistical quality data can also be used with ZEISS PiWeb to compare the quality of different lines or to better estimate casting tool downtime.

Quick evaluations and powerful computing simultaneously

The minimal cycle time of a ZEISS VoluMax system depends entirely on the scanning time because the reconstruction and evaluation of the 3D data is performed parallel to the measuring process. With multiple high-performance computers running at the same time, it is even possible to perform challenging image evaluations in the given cycle time.

Manual loading – safe and fast

By configuring the ZEISS VoluMax with manual loading, the operator is protected by a safety sensor when using the machine. If the operator is outside of the safety zone, then the sliding door opens within just a split second. During loading, an absorbing screen is positioned in front of the X-ray tube to ensure that no X-rays escape. After the machine is loaded and the operator has left the safety zone, the door is closed automatically and the inspection begins.

ZEISS VoluMax Platforms and Customized Automation Options



| Platform type | VoluMax 400 | VoluMax 800 | VoluMax 1500 |
|-------------------------------------|-------------------|--|--------------------|
| Source/detector distance | 400 mm | 800 mm | 1,500 mm |
| Scan volume | dia. 160 x 95 mm | dia. 170 x 150 mm | dia. 350 x 300 mm |
| Scan volume with detector extension | dia. 260 x 325 mm | dia. 300 x 390 mm | dia. 600 x 625 mm |
| Tube types, alternatives | 39 W | 39 W 1,600 W 1,800 W | 1,600 W 1,800 W |
| Detector resolutions, alternatives | 1920 x 1536 Px | 1920 x 1536 Px 1024 x 1024 Px 512 x 512 Px | 1024 x 1024 Px |

Tube types

| Power | Type | Voltage | Focal spot |
|---------|-------------|---------|-------------------------------|
| 39 W | Closed tube | 130 kV | 5/8/20/40 μm |
| 1,600 W | Closed tube | 225 kV | 250/300/500/800 μm |
| 1,800 W | Closed tube | 225 kV | 400/1,000 μm |

VoluMax



Example 1: A simple conveyor belt

The test components are loaded and moved using a conveyor belt and, as an option, a lift element. The conveyor belt also serves as a buffer.



Example 2: A conveyor belt solution running through the machine

A conveyor belt running through the computer tomograph means less time is lost loading and unloading.



Example 3: A robot solution

By using a robot, the ZEISS VoluMax can be integrated into a production line automatically.



ZEISS CT Solutions

Software

With ZEISS software, you use ZEISS CT machines efficiently and utilize their potential to the fullest. Hardware and software are compatible to ensure optimal reliability and productivity. As your one-stop partner, ZEISS is your contact for all your questions about computed tomography and its many potential applications.

ZEISS METROTOM OS machine software

ZEISS METROTOM OS is the operating and machine software for all types of ZEISS METROTOM and ZEISS VoluMax CT machines. The volume data generated by the software serve as the basis for subsequent dimensional evaluations or special 3D visualizations. For X-ray analysis with ZEISS CTs, ZEISS METROTOM OS provides a clearly structured and easy-to-understand user interface and numerous settings for different components. During the operation of the ZEISS VoluMax, ZEISS METROTOM OS is running in the background after the measurement parameters have been stipulated.

ZEISS METROTOM OS features

An array of functions for improving the image in ZEISS METROTOM OS help to generate sharp and high-contrast images, even for complex components made of different materials, e.g. plastic and copper. The detector surface can be extended virtually by using the 'Connect volume' and 'Extend horizontal detector' functions, enabling the scanning of components whose projection extends beyond the detector. The 'Volume separation' function enables the time-saving inspection of multiple small components based on only one scan.

User interface for the ZEISS VoluMax

ZEISS METROTOM OS runs in the background while the ZEISS VoluMax is being used for day-to-day applications. The user interface has been simplified and has only the key elements so that trained workers in production can operate the ZEISS VoluMax easily and safely. Important information concerning the inspection status and the inspection results are displayed clearly. The user interface can, as needed, be modified to meet particular requirements.

ZEISS CALYPSO evaluation software

ZEISS CALYPSO, the standard software for coordinate measuring technology, can be used for the metrological evaluation of ZEISS METROTOM CT data. Measurement plans can be created intuitively with ZEISS CALYPSO by selecting the characteristics used in the CAD design drawing. Size, shape and position tolerances can be taken directly from the CAD model. ZEISS CALYPSO measurement plans which have been written for a ZEISS bridge-type measuring machine can be used with ZEISS METROTOM CT without any modifications. The results are optimally comparable because the same evaluation strategy is used.

In addition to the measurements themselves, ZEISS CALYPSO also offers the possibility of comparing measurement data sets with the CAD model. A color-coded, easy-to-interpret display of the geometry comparison provides information quickly and clearly about the dimensional stability of the entire workpiece.

ZEISS CT Solutions

Software

ZEISS visualization and evaluation software

The software delivers informative 3D visualizations and section views based on the voxel data generated by ZEISS METROTOM OS. Jobs such as pore analysis as well as defect and assembly inspection can be performed effectively with the software. In addition to visualization, the program also provides information on the shape, size and position of characteristics such as discontinuities and inclusions. Metrological evaluations can also be performed effectively.

The voxel data outputted by ZEISS METROTOM OS meet market standards and are compatible with non-ZEISS software.

ZEISS Reverse Engineering for efficient tool correction

The ZEISS Reverse Engineering software provides ready-for-use CAD data for correcting injection molding tools based on only one CT scan. Usually one single correction loop is sufficient to finish machining a tool. This can shorten the correction process and consequently the time to market by weeks.

Here is how the correction process works: first, a smoothed surface model is created from the CT volume model (voxel data). This is called reverse engineering. On this basis, the deviation of the real component from the CAD nominal data is determined. This deviation is then inverted and transferred to the CAD data of the component. A particular benefit of the ZEISS Reverse Engineering software is the ability to stipulate continuity conditions. These can be easily modified to fit the particular component shape and the shrinkage behavior of the material used.

ZEISS PiWeb quality data management

Evaluations and visualizations on the basis of 3D X-ray scans can be made available online worldwide using ZEISS PiWeb. In addition to other quality and process data, the CT results can be used at every stage in the industrial process. Informative diagrams, statistical analyses and CAD displays visualize the captured data and enable the optimal monitoring of all production processes.

ZEISS PiWeb highlights

- With ZEISS PiWeb, the measurement data from various components and measuring machines can be merged quickly in a single measurement report.
- Templates for diagrams, plots and tables make it easy for first-time users and provide the foundation for customized reports.
- Non-ZEISS and manual measuring machines can be easily integrated via open interfaces.
- With ZEISS PiWeb, the C_p and C_{pk} process suitability indices for the statistical evaluation of production quality can be outputted.
- ZEISS PiWeb is easy to configure.

ZEISS METROTOM - New Project



File Edit Help

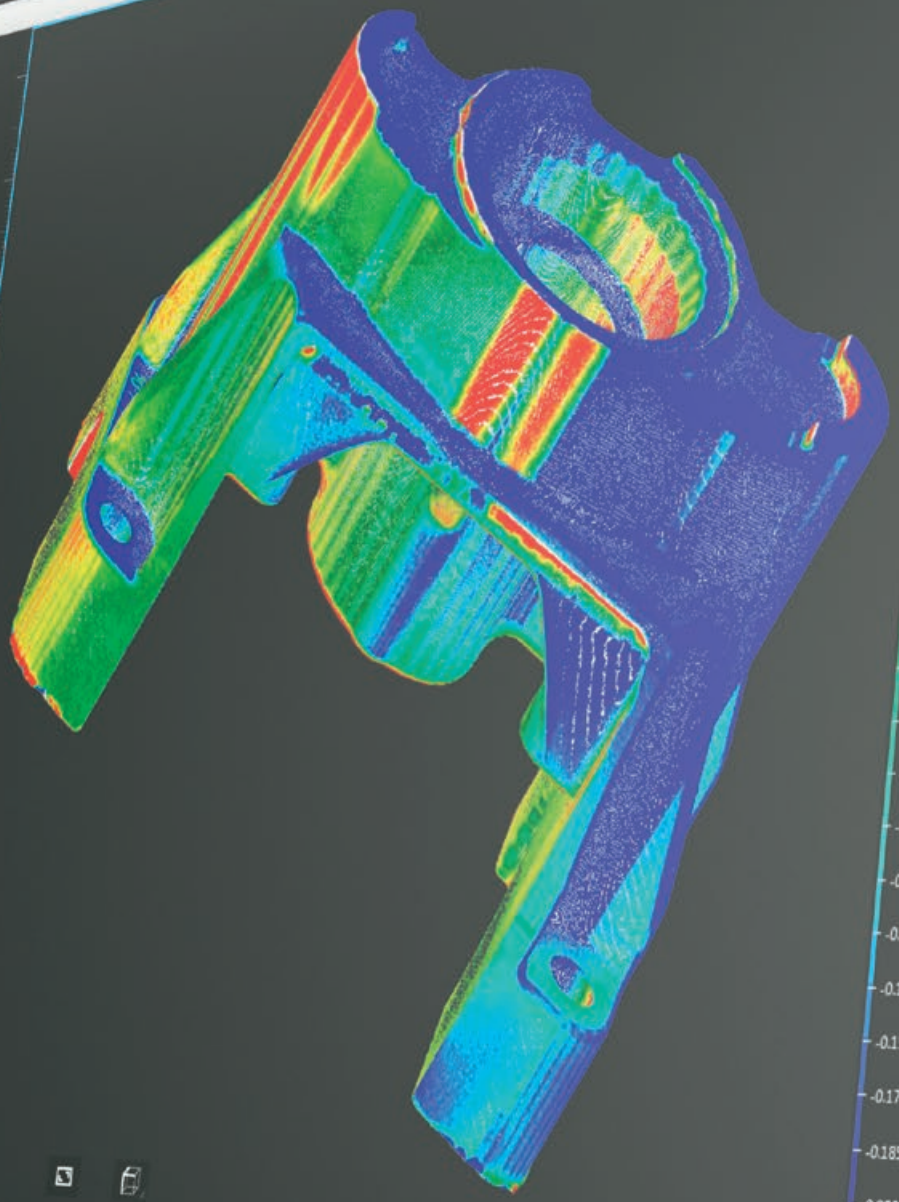
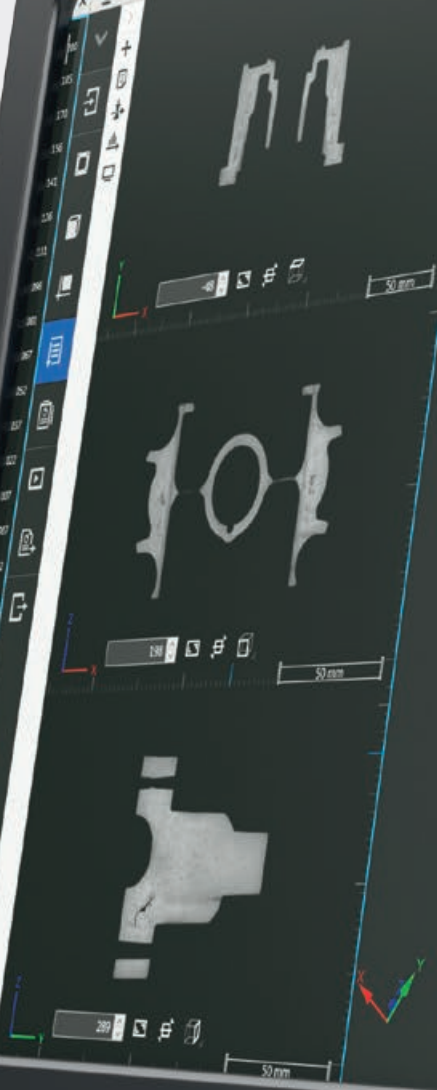

10 mm

ZEISS CT Solutions

After Sales Services

- Manufacturing sites
- Sales and service companies
- Competence Centers
- ◆ Sales partners

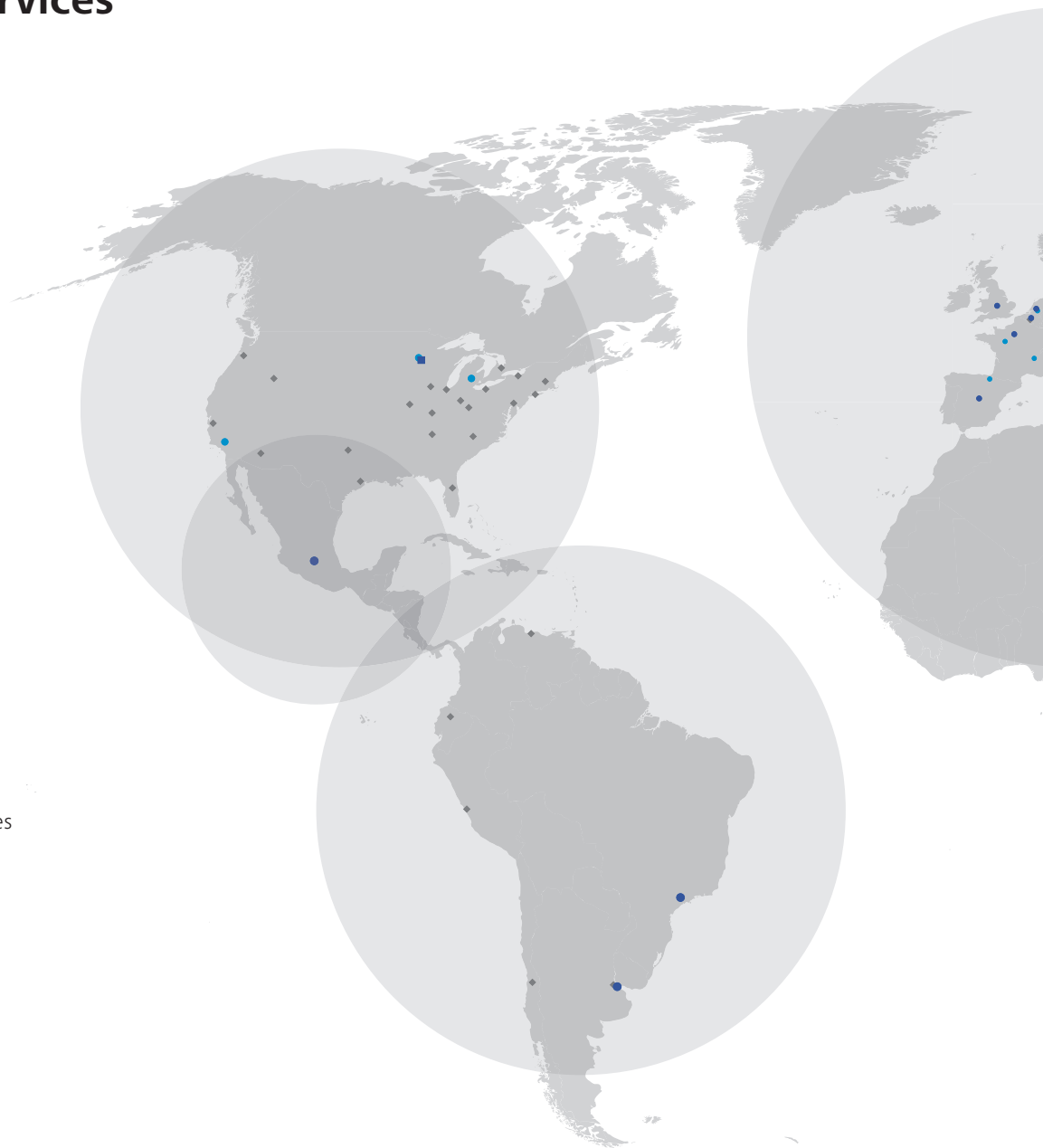

Strong service

Over 750 service and application technicians work for ZEISS worldwide. Thanks to our regional structure, experts and spare parts are available quickly. When it comes to service, you will benefit from our more than 90 years of experience in industrial metrology and our one-stop service offering.

Well maintained – optimally installed

Keep your ZEISS Computer Tomograph ready for use and your software up to date. ZEISS offers maintenance agreements for machine service and ongoing software updates. This way you ensure that you always work optimally and productively.



Invest in knowledge

ZEISS offers a wide range of training courses especially for CT technology and for metrology in general. These include training courses for effectively using your CT machines as well as training courses for performing your own maintenance. You can also book our proven training programs for all software products from ZEISS. Our multi-step, manufacturer-neutral AUKOM training courses also teach general metrological know-how.

Service program for the ZEISS VoluMax

Uptime is crucial because the ZEISS VoluMax is used directly in the production process. So ZEISS offers its own service program for VoluMax CT machines with three different service levels:

- Intensive training and consultation for in-house maintenance
- A telephone hotline
- Fast on-site service

By providing you with intensive training for on-site maintenance and a tele-

phone hotline, we do our best to ensure that you can help yourself should the need arise. This is the most effective method for preventing downtime. In exceptional cases where a ZEISS application technician needs to come to your site, our extensive service network ensures that we will be there quickly. We offer customized maintenance strategies based on the required machine uptime. We perform scheduled maintenance on a day that is suitable for you and in line with your shift model.

ZEISS CT Solutions

CT inspection services

You do not need to have a ZEISS computer tomograph to be able to benefit from ZEISS CT technology. Our measuring houses can perform different CT inspection services for you. If you are interested, please visit our measuring houses to try out ZEISS CT solutions risk free.

Dimensional measuring technology with the ZEISS METROTOM

We create metrological evaluations for the interior and exterior structures of a component. That is why we use the ZEISS METROTOM and ZEISS CALYPSO.

Our services include:

- Measuring standard geometries and freeform surfaces
- Nominal/actual geometry comparison with a color-coded 3D visualization
- Complete initial sample test report

ZEISS METROTOM CT scans

We create ZEISS METROTOM volume data as a separate services for those who use the ZEISS CALIGO, CALYPSO or reverse engineering software products. This ensures that various defects can be analyzed, metrological evaluations can be performed and reverse surface engineering can be created at any time.

Detecting and analyzing defects with the ZEISS VoluMax

On the basis of a CT scan performed with a ZEISS VoluMax, we search and examine defects in plastic and light metal components without destroying them.

Our services include:

- Porosity and inclusion analysis
- Damage and failure analysis
- Mounting checks
- Assembly checks

Reverse engineering with the ZEISS METROTOM

Computed tomography with the ZEISS METROTOM enables you to completely and precisely capture the deviation of a workpiece from the CAD nominal data. These differential data can be used for the targeted correction of tool geometry. Our specialists will help you generate corrected CAD data for your injection molding or casting tools which are in line with your specifications and particular needs.

X-ray microscopy with the ZEISS Xradia Versa

From the layers of a thermal shield coating to individual fibers in carbon fiber components and neurons in brain tissue – we visualize minuscule structures with ZEISS Xradia Versa X-ray microscopes for you. Xradia Versa machines offer a resolution from 0.7 μm and a minimal voxel size from 70 nm. This allows 3D analyses in the submicron range. The special thing about these machines: the resolution of the ZEISS Xradia Versa does not diminish, even for larger components with a diameter up to 300 mm and a correspondingly large working distance.



Carl Zeiss
Industrielle Messtechnik GmbH
73446 Oberkochen/Germany
Sales: +49 7364 20-6336
Service: +49 7364 20-6337
Fax: +49 7364 20-3870
info.metrology.de@zeiss.com
www.zeiss.de/imt

Carl Zeiss
Industrial Metrology, LLC
6250 Sycamore Lane North
Maple Grove, MN 55369/USA
Phone: +1 763 744-2400
Fax: +1 763 533-0219
info.metrology.us@zeiss.com
www.zeiss.com/metrology

Carl Zeiss
Microscopy GmbH
73446 Oberkochen/Germany
Phone: +49 7364 20-4488
Fax: +49 7364 20-3226
info.microscopy.de@zeiss.com
www.zeiss.com/microscopy